

SIEMENS

Whitepaper

Optimizing drive systems for energy savings

usa.siemens.com/motioncontrol

Table of contents

Abstract	3
Introduction	3
Saving energy with a common DC bus	3
PWM technology review	3
AC / AC drive systems	4
Common DC bus architecture	5
Active front end technology (AFE)	6
Power factor savings	6
Eliminating mechanical losses	7
Eliminating gearboxes with direct drive torque motors	7
Driven unwinds vs. mechanical brakes	8
Drive optimization (mechatronics)	9
Optimally sizing for Energy savings	9
Mechatronics and drive tuning for energy savings	9
Replacing existing DC drives with AC	9
Efficiency comparison	9
Enhanced drive system efficiency	10
Motor efficiency / pump and fan losses	10
Energy efficient across the line motors	10
Pump and fan losses	11
Conclusions	11
References	11

prepared by:

William B. Gilbert
 Converting Solutions

Siemens Industry, Inc.
 5300 Triangle Parkway, Suite 100
 Norcross, GA 30092

phone: (770) 625-5658
fax: (770) 871-3888

e-mail: william.gilbert@siemens.com
web: www.usa.siemens.com/converting

Abstract

Several areas should be considered when looking for potential opportunities to reduce energy consumption via the drive system.

The use of a common DC bus architecture as an alternative to individually powered AC drives will conserve energy by sharing the normally wasted regenerative energy from unwinds and other regenerating driven sections. In addition to sharing and saving energy, true common DC bus systems also conserve energy by eliminating many of the typical energy wasting system components.

Utilizing active front end (AFE) power sections to reduce system power factor and harmonics. Active front end power sections provide near-unity power factor and produce minimal harmonics. AFEs can also compensate for the effects of poor power quality issues.

Reducing mechanical losses with direct drives, certain power transmission components can waste significant energy.

Optimizing drive sizes and tuning through mechatronic practices and tools. Oversized drives will use more power and adversely affect the system power factor. Poorly-tuned drive systems can be a common source of energy waste.

Retrofitting older DC drive systems with more efficient AC drive systems. AC drive systems offer greater energy efficiency over older DC technology. Some AC drives can automatically reduce their magnetizing current under low load conditions

Utilizing energy-efficient motors for across the line applications and AC drives in front of the motors in place of mechanical dampers and valves.

Introduction

Energy savings are an extremely important topic in virtually every segment of industry today. This paper will discuss the ideal areas where energy savings can be realized from the major power consumers in converting lines and machinery.

In general, the largest consumer of power in a converting line or machine is the drive system. As energy costs continue to increase and energy conservation becomes a greater priority, are there technologies or methods that can be implemented to reduce the energy consumption on converting machinery?

Saving energy with a common DC bus

PWM technology review

Before we look into the details and benefits of DC Common bus drive systems, let's first take a look at the typical stand alone AC drive. The power design of today's pulse width modulated AC drive is made up of three sections. The input section is the rectifier which converts single or three phase AC voltage into DC voltage. The DC link is the middle section which contains a capacitor bank to smooth and buffer the DC voltage. And third, the fast switching inverter section which pulses the DC voltage into a three phase power signal suitable for an inverter duty rated AC motor.

Figure 1
Stand-alone AC / AC drive

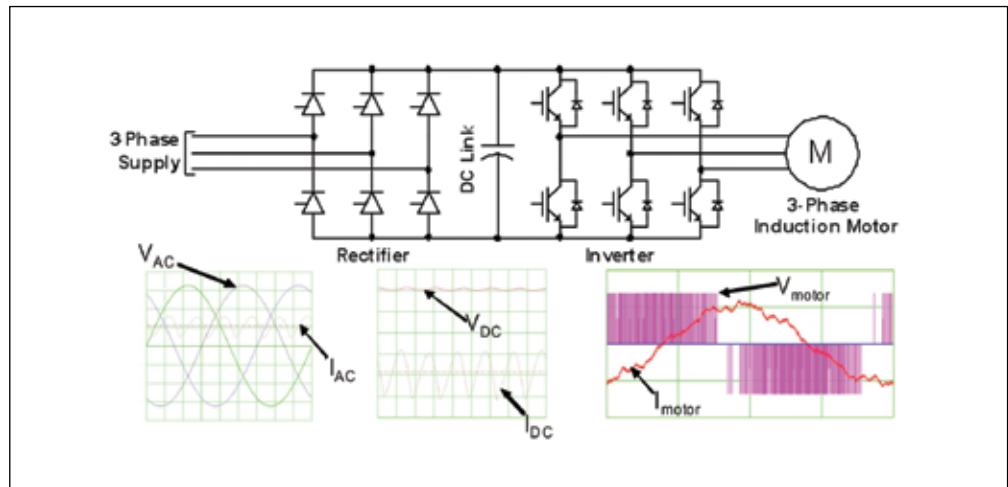

AC / AC drive systems

Figure 2 shows the configuration of standard AC / AC drives that are applied in a multi-axes coordinated drive system. Here each individual drive is connected to the AC line via individual line components (fuses, reactors, contactors and component wiring). Each drive section must deal with its regenerative power individually.

Lets consider a drive system for a converting line with an unwind, pull roll master section, coater, laminator and rewind. Notice how in this scenario the machine sections that add tension to the web (unwind and laminator) must return their power to the drive, and in turn this energy is subsequently disipated (wasted) by the regen resistors connected to the individual drives. Here, 75A of current is wasted as heat.

In some cases a Pseudo-Common DC bus is created with AC / AC drives that have an external bus connection by wiring the bus connections together. However this application is problematic as the current carrying capability of these bus connections do not always match the drive power rating. Precautions also must be taken to prevent the smaller drives from charging the larger drives. In any case, the added components required to create a pseudo-common DC bus is costly and inefficient.

Figure 2
AC / AC coordinated drive line-up

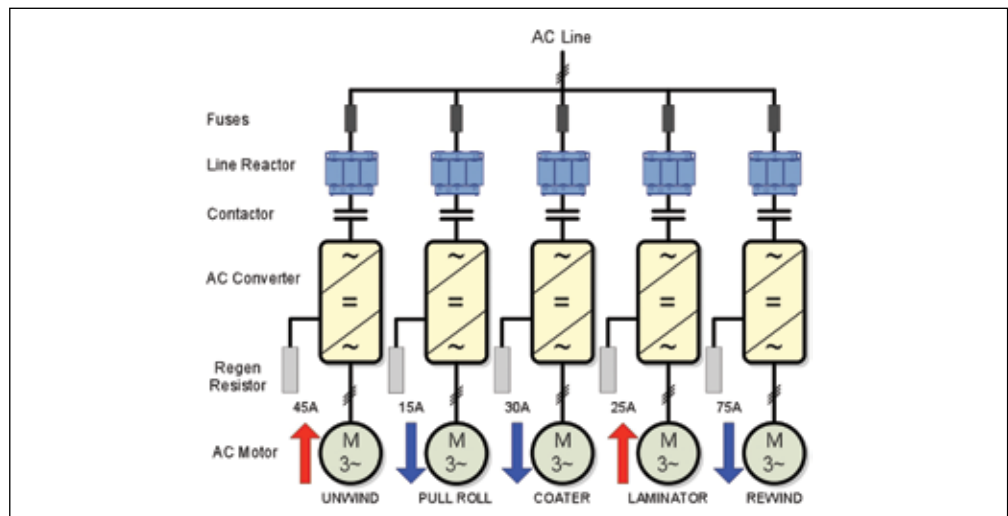

Common DC bus architecture

True common DC bus drive systems are far more efficient than the system composed of stand alone AC / AC drives in several ways. When drive systems utilize a common DC bus design, a shared rectifier section is used to convert the AC power supply into a DC bus which is common to the parallel connected motor modules (inverters).

Power sharing is now permitted between each different drive sections linked on the DC bus. When power sharing occurs on the DC bus between drives that are motoring and generating simultaneously, the drive system now uses less power from the rectifier as the generating drive sections can return their power to the DC bus to be shared by the motoring or consuming drive sections.

In the same example as above, the common DC bus system will use almost 75A less than the AC / AC drive system

Additionally, the line components (i.e. contactor, reactor, fuses, etc.) and rectifier can be sized based upon the maximum current draw of the system not the summation of the individual motors. This also results in a more size optimized and energy efficient design as losses are realized in each individual line component and rectifier.

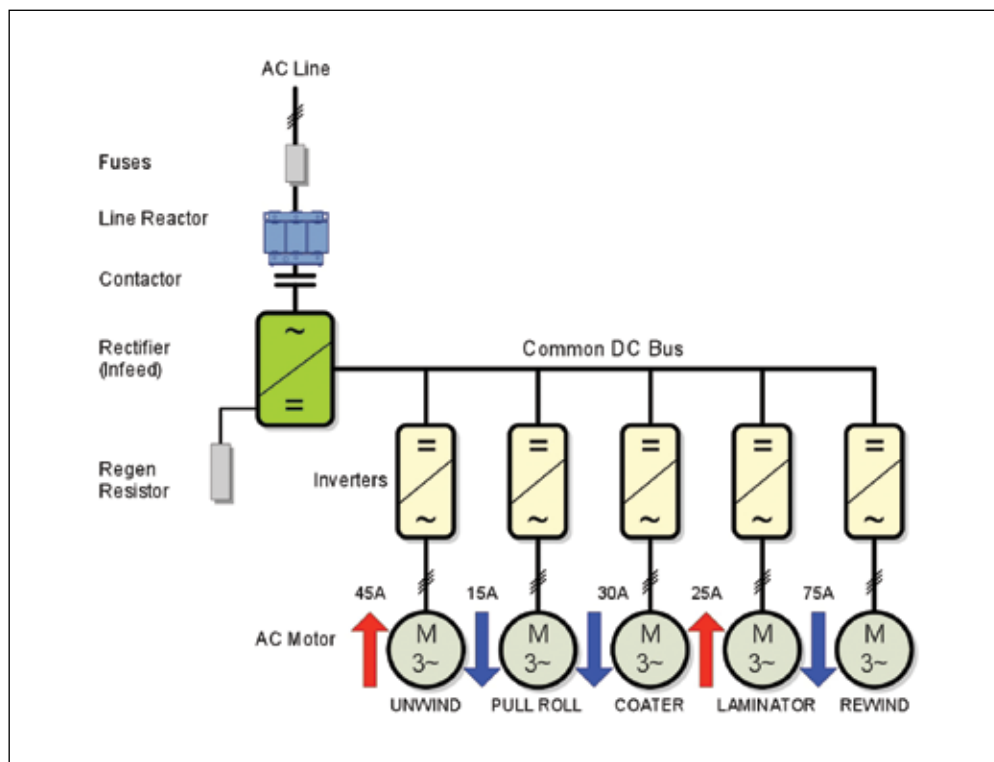

Figure 3
Common DC bus coordinated drive line-up

Active front end technology (AFE)

Active front end infeed technology takes the DC common bus system to a level of additional energy savings. An active front end, or AFE, is an IGBT-based rectifier that regulates or controls the DC bus level, for both over and under voltage. This type of rectifier is suitable as a substitute or replacement for the basic or regen SCR-based modules discussed in the common bus overview.

In addition to line regen capability, this functionality also allows the input voltage and current waveforms to the drive to be sinusoidal, prevents harmonics from being generated back to the line and offers near unity power factor. Although the reduction in harmonics can be very important to plant operation, the main energy savings from the AFE come from the improvement in power factor. AFE controlled drives can have a .99+ power factor. In Figure 4, the effective line current in a Diode bridge rectifier and AFE rectifier is detailed.

Figure 4
Comparison of line current
Diode Bridge vs. AFE Rectifier

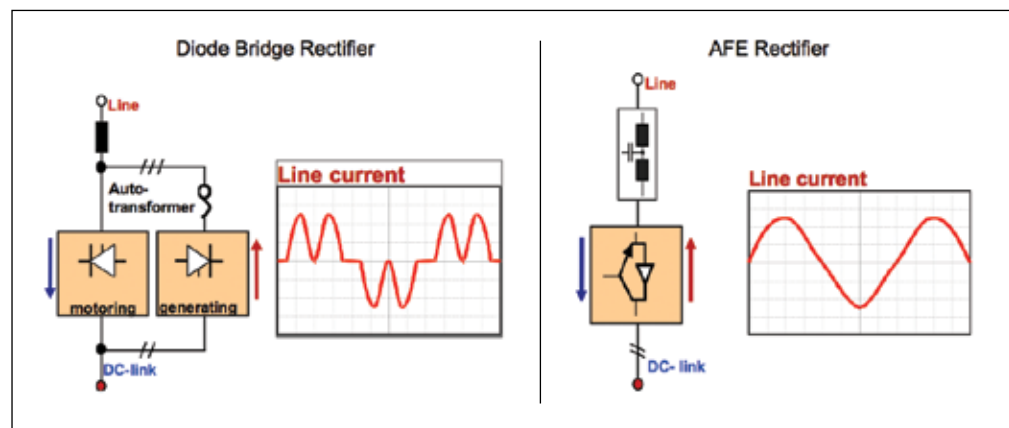

Power factor savings

Power factor is a measure of how effectively electrical power is being used. A high power factor (approaching unity) indicates efficient use of the electrical distribution system while a low power factor indicates poor use of the system.

Power factor is the ratio of real power to apparent power. To determine power factor (PF), divide real power (kW) by apparent power (kVA). In a sinusoidal system, the result is also referred to as the cosine θ .

When a utility serves an industrial plant that has poor power factor, the utility must supply higher current levels to serve a given load. A utility is paid primarily on the basis of energy consumed and peak demand supplied. Without a power factor billing element, the utility would receive no more income from the second plant than from the first. As a means of compensation for the burden of supplying extra current, utilities typically establish a "power factor penalty" in their rate schedules. A minimum power factor value is established, usually 95 percent. When the customer's power factor drops below the minimum value, the utility collects "low power factor" revenue.

Eliminating mechanical losses

There are two major areas in converting machinery where significant energy is lost through friction and mechanical inefficiency. The first is mechanical drive systems or gear boxes with high ratios. The second is on unwinds with mechanical tension control brakes.

Eliminating gearboxes with direct drive torque motors

High gear ratios are required when optimizing motor sizes when driving large diameter rolls or on very low speed web applications. Where planetary gearboxes are fairly efficient, high ratio multi-stage worm gear boxes can easily have efficiencies under 60 percent.

Low speed and applications and driven sections that previously looked to inefficient gearboxes are commonly becoming direct driven with torque motors and even conventional motors, thus eliminating the energy losses. Typical applications on converting lines utilizing torque motors with direct drive are chill rolls, large diameter casting rolls and very low speed web control in applications such as sputtering metallizers.

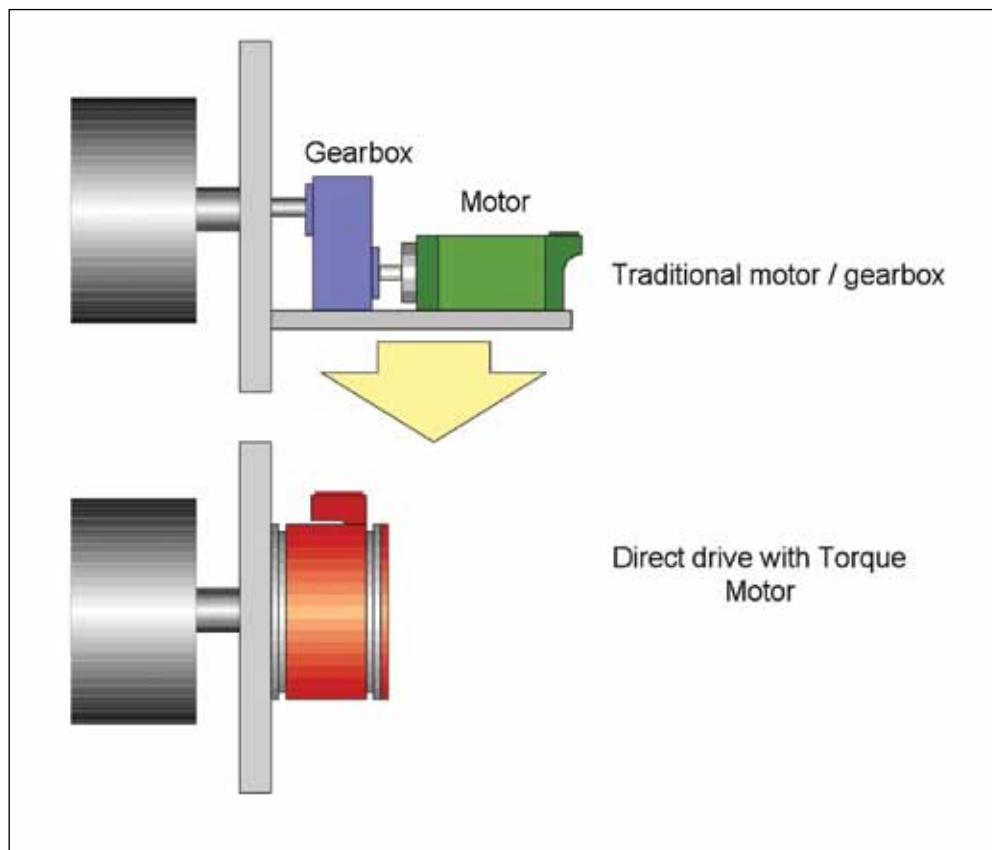

Figure 5
Gear drive vs. direct drive

Driven unwinds vs. mechanical brakes

Unwinds with mechanical brakes are an ideal source where energy can be recovered. Mechanical brakes create web tension from friction, the heat created in this process is in effect energy that can be recovered.

Pneumatic or electromechanical tension control brakes are commonly replaced with an AC drive system with line regenerative capability.

Figure 6
Mechanical brake unwind

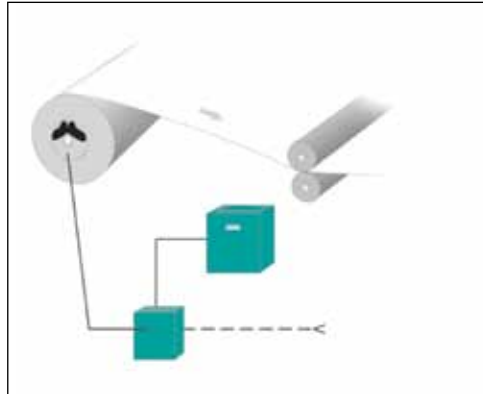

A driven unwind must return the tension energy back to the AC line. In the past, regen DC drives have been successfully applied in these applications, but DC drive systems are no longer common and even during their prime were very costly when compared to their mechanical counterparts. Early on in the AC drive technology, the drives did not have the capability to regenerate the power back to the AC line and when applied as unwind brakes, required regen resistors to dissipate the tension energy. This was wasteful and costly.

Today's AC drive systems now have the technology to regenerate the energy back to the AC line just as the DC drive did, but with added benefits to the user and machine designer alike. Sending the tension energy back to the line means power that once was wasted can now be retained, instead of the system producing heat and worn parts. Additionally if the drive is equipped with active front end technology, it will return the energy with near unity power factor, something not possible for any DC drive system.

Figure 7
Driven unwind

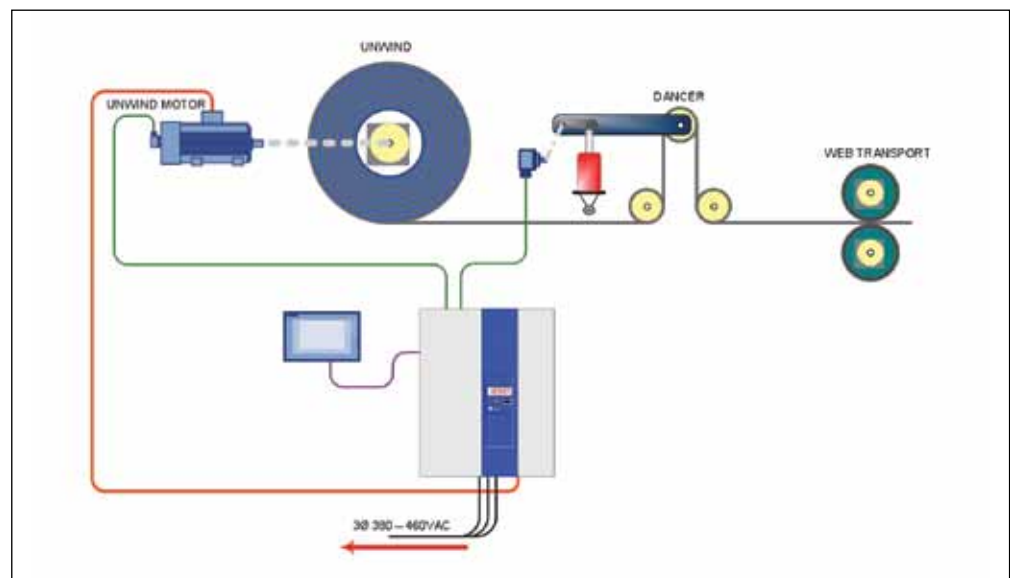

Drive optimization (mechatronics)

Paying attention to drive and motor sizes versus actual load requirements for the specific application and making sure that that coordinated drives are properly tuned is a point that will aid in energy savings.

Optimally sizing for energy savings

Oversized drive systems simply waste energy. The cost of energy waste is realized in the higher magnetizing current. An AC drive system's magnetizing current can be nearly half of the full load current (FLA). Consider an example of a 100hp AC drive system applied to an actual 30hp load requirement. In this example, 34 amperes of line current is wasted.

100HP			30HP		
FIA motor current	125.0	A	FIA motor current	40.0	A
Magnetising current	50.0	A	Magnetising current	16.0	A

Figure 8
Single drive energy savings

That relates to an energy savings of = 34A for a single drive.

Mechatronics and drive tuning for energy savings

Poorly tuned drives not only can affect machine performance and product quality but waste significant energy. Drive systems that are tuned beyond the optimal can waste energy as they drive the current loop harder. The overactive current loop will waste energy as heat in the motor

As industry trends push the drive systems performance, mechatronics can insure higher performance without wasting energy. The Main issues can arise from:

1. Complex loads
2. Compliance
3. Lost motion
4. Machine resonances

Applied mechatronics support can help to archive the required system performance without wasting energy and affecting machine life

Replacing existing DC drives with AC

Replacing outdated DC drive and motor systems with AC drive technology can offer energy savings from the improved energy efficiency of the AC system over its DC counterpart. In addition, savings from improved power factor can also be realized

Efficiency comparison

While the DC motor without regard to the drive is more efficient than an AC motor, the AC PWM Drive is far superior to a DC SCR drive. When considering drive system efficiency, the AC drive system can offer an efficiency improvement in the range of ~3 percent when operating at near full load, where the DC drive efficiency is at its highest.

Consider the example of single stand alone drive systems both at 100hp, running at 90 percent load, 12-hours a day, and 7-days a week. Just a single AC / AC drive replacement can provide over \$1000.00 of energy savings per year.

Figure 9
Drive system efficiency

system	drive efficiency (%)	motor efficiency (%)	system efficiency (%)	kWH / year	anual power cost
DC	99.0%	88.0%	87.1%	336,625	\$26,930
AC	97.0%	93.5%	90.7%	323,356	\$25,868

Kilowatt Hours — $\text{hp} \times .746 \times \text{Annual hours of operation} / \text{system efficiency}$
 100hp motor is running at 90 percent load; 12-hours per day, 7-days a week
 Assume \$.08 / kWh

Enhanced drive system efficiency

Drive technology continues to tend to energy savings, a recent drive feature that is available in some drives aids the drive system in energy savings by reducing the AC motors magnetizing current under no or light load conditions. As discussed earlier, asynchronous motor magnetizing current can approach half of the full load motor current. This means that drives that remain enabled under no or light loads can realize significant energy savings from the drive system.

Motor efficiency / pump and fan losses

In certain conditions across the line AC motors are used in converting lines. Typical applications for these include pumps and fans.

Energy-efficient across the line motors

Modern standards for NEMA and IEC motors offer vastly improved efficiency. Consider replacing older AC Motors with High efficiency motors. There are currently three levels of motor efficiency.

- Standard efficiency and IEC IE1; — pre-EPAAct, least efficient
- NEMA high-efficiency and IEC IE2; — EPAAct level, more efficient
- Nema premium and IEC IE3; — best efficiency

Figure 10 details potential savings from single 100hp AC motor running at 90 percent load

Figure 10
Savings from improved motor efficiency

efficiency rating	system efficiency (%)	kWH / year	anual power cost	anual savings
Standard efficiency	93.5%	348,506	\$27,880.45	
High-efficiency IEC IE3	95.0%	343,003	\$27,440.24	\$440.22
NEMA premium IEC IE3	96.2%	338,724	\$27,097.95	\$782.51

Kilowatt Hours — $\text{hp} \times .746 \times \text{annual hours of operation} / \text{system efficiency}$
 100hp motor is running at 90 percent load; 12-hours per day, 7-days a week
 Assume \$.08 / kWh

Pump and fan losses

In the applications where across the line motors are utilized such as flow control, energy savings can be acquired by adding an AC drive. The biggest potentials for saving are offered by pumps, fans, and compressors that are still operated with mechanical throttles and valves. Converting to variable-speed drives can produce considerable economic benefits.

Changing the flow mechanically vs. controlling the flow with an AC drive has many disadvantages. With mechanical flow control, the motor runs continuously at the speed required for the maximum delivery rate, which is rarely needed in practice. Additionally, throttles and valves lose energy and cause high temperatures and vibration levels which can have a negative impact on the drive and production operation.

Variable speed drives with inverters offer a more economic alternative for a number of reasons. They can be controlled much more quickly and precisely. But mainly, by adapting the flow rate directly to actual requirements, energy savings of up to 60 percent can be achieved, especially in energy-intensive applications. Consider the comparison of a mechanical throttle to speed control example in figure 11 for an overview of typical losses. In this example, the input power requirement of the driven fan or pump is only 56 percent of the input power requirement of the mechanical throttle example.

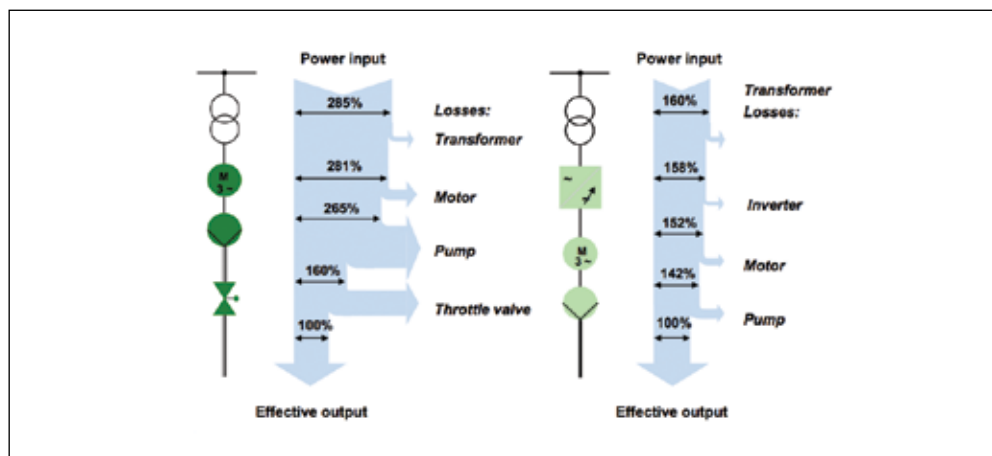

Figure 11
Mechanical throttling vs. speed control

Conclusions

Drives and driven systems in converting lines are major energy consumers, but advances in technology continue to offer multiple avenues of reducing the total energy costs. In this paper, we have addressed some of the major places where energy savings or recovery can be found on converting lines and machinery. As technology continues to make advancements in drive systems, more saving options will soon follow.

References

- [1] Craig Nelson, "Multi-Axis Drive Applications using Common DC Bus", White Paper, Siemens
- [2] ARC Advisory Group, "A Strategic Roadmap for Sustainable Management and Energy Efficiency for Industrial, Commercial, Municipal and Manufacturing Operations" ARC White Paper, 2009

Siemens Industry, Inc.
5300 Triangle Parkway, Suite 100
Norcross, GA 30092
1-770-871-3800
mcs.convertimg.industry@siemens.com
Order No. INWP-DRIVE-0412
Printed in USA
© 2012 Siemens Industry, Inc.
usa.siemens.com/motioncontrol

This brochure contains only general descriptions or performance features, which do not always apply in the manner described in concrete application situations or may change as the products undergo further development. Performance features are valid only if they are formally agreed upon when the contract is closed.

Siemens is a registered trademark of Siemens AG. Product names mentioned may be trademarks or registered trademarks of their respective companies. Specifications are subject to change without notice.