

Use of Process Analytics in Cryogenic Air Separation Plants

Chemical Industry Case Study

For further treatment of primary and intermediate materials, large amounts of oxygen and nitrogen are required by many industries, e. g. chemical and petrochemical, metal, semiconductor and food industry, in machine construction and many others. Oxygen and nitrogen are, together with Argon, the main constituents of ambient air. They are obtained from there by means of the air separation technology in highly automated air separation plants. Siemens is a leading supplier of Process Analytical Instrumentation and offers very capable gas analyzers which meet perfectly the demanding requirements of air separation plants. Furthermore, Siemens offers complete analytical solutions from planning and engineering up to installation and maintenance. This Case Study explains the cryogenic air separation process and the related analysis tasks.

Air separation

The composition of dry air is approximately (by volume) 78% nitrogen, 21% oxygen, and 1% argon plus small amounts of noble gases, carbon dioxide, traces of hydrocarbons and other impurities. Oxygen, nitrogen and argon are required as

industrial gases in large quantities and with a high degree of purity. Therefore, processes have been and are further developed to produce these gases through the separation of air. While there are variations in process details, all air separation plants employ one of two types of process technology:

- Air separation at very low temperatures to liquefy the air and to produce the desired products by subsequent distillation (cryogenic process) based on differences in boiling points or
- Air separation at higher pressure using adsorption effects based on differences in specific properties of the gases (pressure swing adsorption, PSA).

All cryogenic air separation processes from air as raw material to oxygen, nitrogen or noble gases as products consist of a similar series of steps independently whether large stand-alone plants or small and compact plants located directly at the consumers place are concerned. Variations reflect the desired product mix and individual priorities of the user. In all cases, process analyzers are required to control and optimize the process.

Cryogenic air separation

The process

Cryogenic air separation processes use differences in boiling points of the components to separate air into the desired products oxygen, nitrogen and argon. These three gases represent about 99% of dry ambient air (see text box). Numerous process configurations are existing caused by the demand of particular gas products and product mixes at various levels of purity. All cryogenic separation processes comprise similar stages (see fig. 1 and 3).

Filtering, compressing and purifying of ambient air

Ambient air is sucked in through a filter and compressed to approximately 6 bar. Then by passing the air stream through a cooler and a mole sieve, contaminants including water vapor, carbon dioxide (which would freeze in the process) and hydrocarbons are removed from the process stream.

The compressed and purified air is then cooled in stages to very low temperature (-180 °C) through heat exchange and refrigeration processes in the main heat exchanger which is located in an insulated container called cold box. Heat exchange occurs in counter current against other streams such as product and waste nitrogen leaving the distillation columns. Products are warmed almost to ambient temperature while the process air is cooled close to liquefaction temperature. Final cooling is achieved by expanding the feed in an expansion engine.

Rectification (Separation)

Separation of air into its components is performed in a two-column rectification system comprising a high-pressure and a low-pressure column (fig. 3).

A liquid oxygen-rich crude feed is produced as bottom product of the high pressure column:

In a counter-current system a gas stream rises up the column while a liquid mixture flows down. High boiling liquid oxygen is formed from the rising gas stream by condensation while, from the liquid, lower boiling nitrogen is evaporated.

Thus, gaseous nitrogen is formed at the top of the column while liquid oxygen is produced at the bottom. By evaporating oxygen from the bottom and feeding fresh nitrogen at the top the process is continued until the desired product purity is achieved. This continuous distillation process is called rectification. Pure nitrogen is finally taken off the overhead of the column.

The oxygen-rich crude feed from the bottom of the high-pressure column becomes feed to the low-pressure column for final separation into pure oxygen (at the bottom) and a oxygen containing nitrogen fraction that is withdrawn from the top of the column. The oxygen is withdrawn from the bottom as product.

Achievable purities depend on the amount of ambient air fed to the process and the number of separation trays of the columns.

Argon is enriched in the middle part of the low pressure column. It can be withdrawn from there and processed to pure argon in additional concentrating steps.



Fig. 2: Typical air separation plant

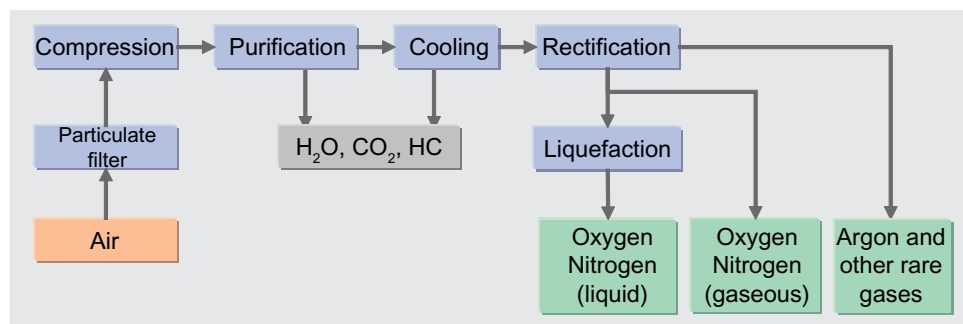

Fig. 1: Air separation, generic flow diagram, simplified

Rectification

Rectification is a thermal separation process and was further developed from distillation. During rectification, liquids containing two or more components are separated into their constituents by multiple evaporation and condensation. This continuously repeated process runs in a vertical column where the rising gas stream interact in counter-current with the condensate liquid that flows down the column (Continuous heat and mass transfer).

Rectification advantages include continuous operation and much higher separation efficiency compared to normal distillation.

Intense contact is required between the gaseous and liquid phases. This is realized by columns internals such as trays, plates or packings.

Composition of dry air [Vol.%]

- Nitrogen 78.09
- Oxygen 20.95
- Argon 0.93
- CO2 0.034
- Neon 0.0016
- Helium 0.0005
- Crypton 0.0001

Analysis Tasks (1)

Analysis demands

Reducing production costs (energy consumption) and ensuring product quality are dominating goals in air separation plant operation. Process gas analyzers are used throughout the process to provide the required data.

Binding specifications exist for the composition of the desired end products with grades of purity up to 99,999 %. Process gas analysis is used to verify the final products to comply with the given specifications.

Energy costs dominate the total production costs and can be kept under control only

through exact monitoring whether the process runs as close as possible to its optimal operation conditions. This requires continuous and reliable process gas analysis of the process streams.

Fig. 3 shows the diagram of a cryogenic air separation plant including typical measuring point locations. Table 1 presents the corresponding measuring tasks and suitable analyzers. The specific design of real plants may deviate from that depending on differing process details and product specifications.

Sampling location	Measuring component	Measuring range	Suitable Siemens analyzers
1 Feed to high pressure column	CO ₂ THC H ₂ O	0...10ppm 0...10ppm	ULTRAMAT 6 FIDAMAT 6 TPA
2 Circle gas nitrogen	O ₂	0...21%	OXYMAT 61
3 Low pressure column, liquid phase	O ₂ CO ₂ THC	98...100% 0...10ppm 0...300ppm	OXYMAT 6 ULTRAMAT 6 FIDAMAT 6
4 Feed to low pressure column	O ₂	0...50%	OXYMAT 6
5 Liquid nitrogen	O ₂ CO ₂ H ₂ O	0...10ppm 0...10ppm	OXYMAT 64 ULTRAMAT 6 TPA
6 Liquid oxygen	O ₂ CH ₄ , C ₂ H ₄ C ₂ H ₆ , C ₃ H ₈	98...100% low ppm ranges	OXYMAT 61 MAXUM
7 Gaseous oxygen	O ₂ THC CO ₂ H ₂ O	98...100% Traces Traces	OXYMAT 61 FIDAMAT 6 ULTRAMAT 61 TPA
8 Gaseous nitrogen	O ₂ THC H ₂ O	0...10ppm 0...10ppm 0...10ppm	OXYMAT 64 FIDAMAT 6 TPA
9 High purity Argon and Krypton	H ₂ , O ₂ , N ₂ CH ₄ , CO	Ultra traces (ppb)	MAXUM with sensitive detector (PDHID)
10 Process air feed before main condenser	CH ₄ , C ₂ H ₄ C ₂ H ₆ , C ₃ H ₈	low ppm ranges	MAXUM
11 Process air before molecular sieve	CO ₂	0...10ppm	FIDAMAT 6

Single analyzer or complete solution

To equip air separation plants with analysis instrumentation, Siemens supplies end users or plant manufacturers either with suitable analyzers or with complete analysis solutions ranging from planning and engineering to installation, commissioning and maintenance of analysis systems

Oxygen analysis

Oxygen is the most important measuring component in air separation plants. Siemens holds a very strong market position in oxygen gas analysis with two analyzer models:

- The OXYMAT 61 is well proven for its high-precision measurement of oxygen in gases up to highest measuring ranges (98 to 100 %) while
- the OXYMAT 64 is especially designed for trace analysis down to the range of 0 to 10 ppm.

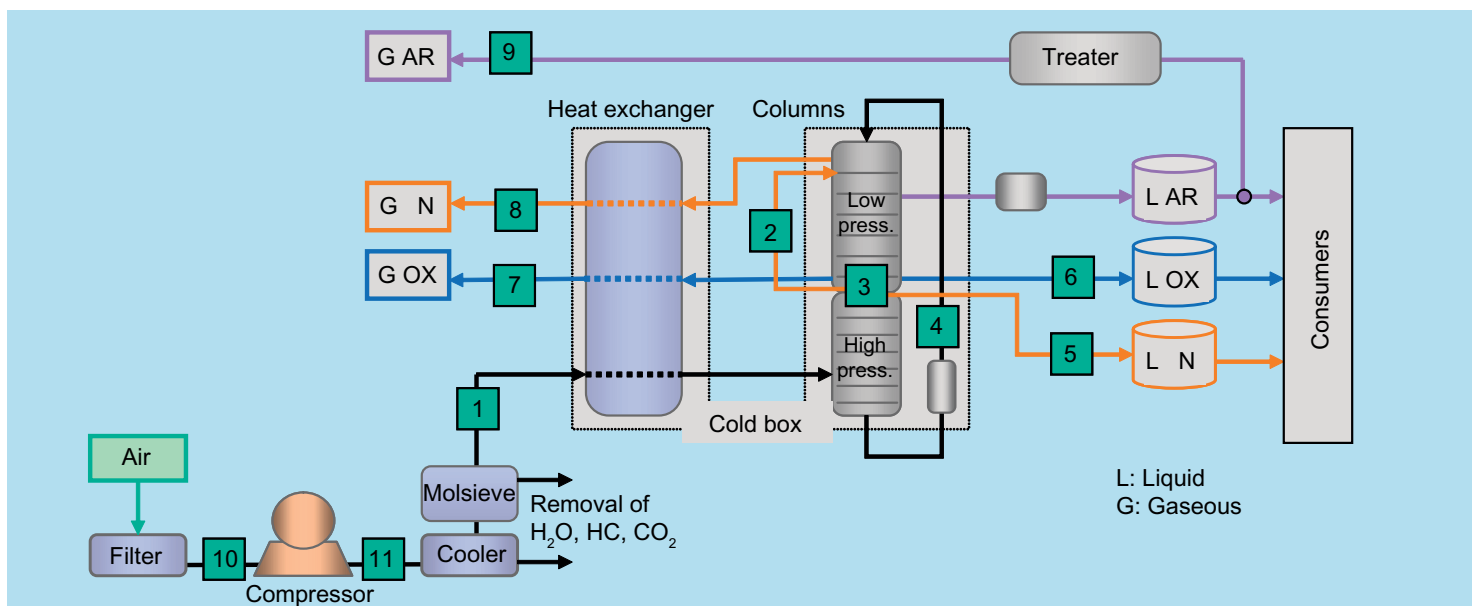

Fig 3: Cryogenic air separation, sampling point locations

Analysis Tasks (2)

Measurement of hydrocarbons

Ambient air used as raw material typically contains small amounts of hydrocarbons. This HC content is important in two respects and must be, therefore, carefully monitored:

- Hydrocarbons in the raw gas tend to condensate and enrich during the cooling process and may form explosive mixtures. Therefore, HC compounds are removed from the process gas prior to the heat exchanger and their concentration is monitored. The FIDAMAT 6 THC analyzer is very much suited for this task. To analyse in particular the concentration of acetylene (which can lead to explosive mixtures very fast) the Process Gas Chromatography MAXUM II is the best choice. It provides detection limits below the ppm range.
- Traces of hydrocarbons may be still present in the final product streams. They must be analyzed with high accuracy and reliability in order to ensure compliance with the product specification set by the consumer. Either the FIDAMAT 6 is used for this analysis task to determine total hydrocarbons (THC) or MAXUM II is used to determine traces of individual hydrocarbons, such as methane, ethane, ethene or propene.

Measurement of oxygen

In air separation plants oxygen must be measured in two concentration ranges:

- High percent oxygen measuring ranges are required for measurements to control and optimize the process and to ensure the quality of the gaseous oxygen product. The OXYMAT 61 is very much suitable for that because it uses a reference gas with selectable oxygen concentration. A reference gas concentration of e.g. 99 % allows to configure a very small measuring range (99-100 %) resulting in extremely high accuracy and stability of the measured data.
- Low ppm oxygen measuring ranges (0 ... 10 ppm) are required for controlling the product quality (purity) of both the nitrogen and argon product streams where oxygen is an unwanted impurity. The OXYMAT 64 trace oxygen analyzer is especially suited for this task.

Measurement of carbon dioxide

CO₂ is a generally unwanted impurity in ambient air feed and therefore removed by refrigeration already prior to the beginning of the process. Measurements are required to monitor the efficiency of the CO₂ removal.

The final product streams must be monitored for traces of CO₂ to assure product quality and compliance with the specification.

The ULTRAMAT 6 NDIR gas analyzer is very much suitable for this application.



Fig. 4: OXYMAT 64 Trace Oxygen Analyzer

OXYMAT 64 - the Trace Oxygen Analyzer

The OXYMAT 64 analyzer belongs to the well known and proved Series 6 of Siemens continuous extractive gas analyzers. Its preferred application area is the determination of very low levels of oxygen in pure gases. The OXYMAT 64 uses ZrO₂ technology with a tubular sensor that is heated continuously to 650 °C. While the sample gas flows through the sensor, the outer side of the sensor is exposed to ambient air which acts as reference electrode. The different oxygen concentration across both sides of the sensor results in different partial pressures causing ions to move and to create a potential difference between both electrodes. This potential difference is a measure for the oxygen concentration in the sample gas.

Key features:

- Smallest measuring range: 0 ... 10 vpm O₂
- Detection limit: 1 % of measuring span
< 0,1 ppm within meas. span 0 ... 10 ppm
- Measured value drift: < 2 % of measuring span / month
- Linearity deviation: < 2 % of measuring span
- Choice of a catalytic inactive or a catalytic active sensor (with different reactivity to combustibles present in the sample gas)
- Menu guided operation according to NAMUR recommendation
- Open interface architecture: RS 485, RS 232, PROFIBUS DP/PA (Option)

Siemens Analytical Products and Solutions at a glance

Siemens Analytical Products and Solutions

Siemens Analytical Products and Solutions is a leading provider of process analyzers and process analysis systems. We offer our global customers the best solutions for their applications based on innovative analysis technologies, customized system engineering, sound knowledge of customer applications and professional support. And with Totally Integrated Automation (TIA), Siemens Analytical Products and Solutions is your qualified partner for efficient solutions that integrate process analyzers into automation systems in the process industry.

From demanding analysis tasks in the chemical, oil & gas and petrochemical industry to combustion control in power plants to emission monitoring at waste incineration plants, the highly accurate and reliable Siemens gas chromatographs and continuous analyzers will always do the job.

Siemens Analytical Products and Solutions offers a wide and innovative portfolio designed to meet all user requirements for comprehensive products and solutions.

Our Products

The product line of Siemens Analytical Products and Solutions comprises extractive and insitu continuous gas analyzers (fig. 5 to 8), process gas chromatographs (fig. 9 to 12), sampling systems and auxiliary equipment. Analyzers and chromatographs are available in different versions for rack or field mounting, explosion protection, corrosion resistant etc.

A flexible networking concept allows interfacing to DCS and maintenance stations via 4 to 20 mA, PROFIBUS, Modbus, OPC or industrial ethernet.



Fig. 5: Series 6 gas analyzer (rack design)

Extractive Continuous Gas Analyzers (CGA)	
ULTRAMAT 23	The ULTRAMAT 23 is a cost-effective multicomponent analyser for the measurement of up to 3 infrared sensitive gases (NDIR principle) plus oxygen (electrochemical cell). The ULTRAMAT 23 is suitable for a wide range of standard applications. Calibration using ambient air eliminates the need of expensive calibration gases.
CALOMAT 6/62	The CALOMAT 6 uses the thermal conductivity detection (TCD) method to measure the concentration of certain process gases, preferably hydrogen. The CALOMAT 62 applies the TCD method as well and is specially designed for use in application with corrosive gases such as chlorine.
OXYMAT 6/61/64	The OXYMAT 6 uses the paramagnetic measuring method and can be used in applications for process control, emission monitoring and quality assurance. Due to its ultrafast response, the OXYMAT 6 is perfect for monitoring safety-relevant plants. The corrosion-proof design allows analysis in the presence of highly corrosive gases. The OXYMAT 61 is a low-cost oxygen analyser for standard applications. The OXYMAT 64 is a gas analyzer based on ZrO ₂ technology to measure smallest oxygen concentrations in pure gas applications.
ULTRAMAT 6	The ULTRAMAT 6 uses the NDIR measuring principle and can be used in all applications from emission monitoring to process control even in the presence of highly corrosive gases. ULTRAMAT 6 is able to measure up to 4 infrared sensitive components in a single unit.
ULTRAMAT 6 / OXYMAT 6	Both analyzer benches can be combined in one housing to form a multi-component device for measuring up to two IR components and oxygen.
FIDAMAT 6	The FIDAMAT 6 measures the total hydrocarbon content in air or even in high-boiling gas mixtures. It covers nearly all requirements, from trace hydrocarbon detection in pure gases to measurement of high hydrocarbon concentrations, even in the presence of corrosive gases.
In-situ Continuous Gas Analyzer (CGA)	
LDS 6	LDS 6 is a high-performance in-situ process gas analyser. The measurement (through the sensor) occurs directly in the process stream, no extractive sample line is required. The central unit is separated from the sensor by using fiber optics. Measurements are carried out in real-time. This enables a pro-active control of dynamic processes and allows fast, cost-saving corrections.

Fig. 6: Product scope "Siemens Continuous Gas Analyzers"



Fig. 7: Series 6 gas analyzer (field design)



Fig. 8: LDS 6 in-situ laser gas analyzer

Siemens Analytical Products and Solutions at a glance (continued)



Fig. 9: MAXUM edition II Process GC



Fig. 10: MicroSAM Process GC



Fig. 11: SITRANS CV Natural Gas Analyzer

Process Gas Chromatographs (Process GC)	
MAXUM edition II	<p>MAXUM edition II is very well suited to be used in rough industrial environments and performs a wide range of duties in the chemical and petrochemical industries and refineries.</p> <p>MAXUM II features e. g. a flexible, energy saving single or dual oven concept, valveless sampling and column switching, and parallel chromatography using multiple single trains as well as a wide range of detectors such as TCD, FID, FPD, PDHID, PDECD and PDPID.</p>
MicroSAM	<p>MicroSAM is a very compact explosion-proof micro process chromatograph. Using silicon-based micromechanical components it combines miniaturization with increased performance at the same time. MicroSAM is easy to use and its rugged and small design allows mounting right at the sampling point. MicroSAM features drastically reduced cycle times, provides valveless sample injection and column switching and saves installation, maintenance, and service costs.</p>
SITRANS CV	<p>SITRANS CV is a micro process gas chromatograph especially designed for reliable, exact and fast analysis of natural gas. The rugged and compact design makes SITRANS CV suitable for extreme areas of use, e.g. offshore exploration or direct mounting on a pipeline. The special software "CV Control" meets the requirements of the natural gas market, e.g. custody transfer.</p>

Fig. 12: Product scope "Siemens Process Gas Chromatographs"

Our solutions

Analytical solutions are always driven by the customer's requirements. We offer an integrated design covering all steps from sampling point and sample preparation up to complete analyzer cabinets or for installation in analyzer shelters (fig. 13). This includes also signal processing and communications to the control room and process control system.

We rely on many years of world-wide experience in process automation and engineering and a collection of specialized knowledge in key industries and industrial sectors. We provide Siemens quality from a single source with a function warranty for the entire system. Read more in "Our Services".



Fig. 13: Analyzer house (shelter)

Siemens Analytical Products and Solutions at a glance (continued)

Our solutions ...

Analyzer networking for data communication

Engineering and manufacturing of process analytical solutions increasingly comprises "networking". It is getting a standard requirement in the process industry to connect analyzers and analyzer systems to a communication network to provide for continuous and direct data transfer from and to the analyzers.

The two objectives are (fig. 15):

- To integrate the analyzer and analyzer systems seamlessly into the PCS / DCS system of the plant and
- To allow direct access to the analyzers or systems from a maintenance station to ensure correct and reliable operation including preventive or predictive maintenance (fig.14).

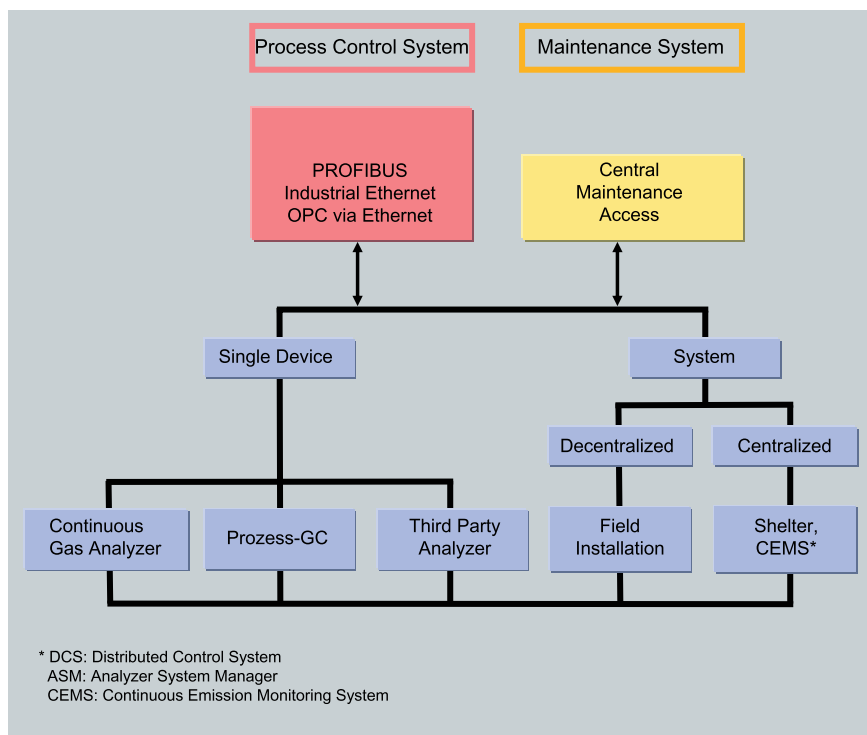

Fig. 15: Networking for DCS integration and maintenance support

Siemens Analytical Products and Solutions provides networking solutions to meet the demands of both objectives.

Our Services

Siemens Analytical Products and Solutions is your competent and reliable partner world wide for Service, Support and Consulting.

Our resources for that are

- Expertise
 As a manufacturer of a broad variety of analyzers, we are very much experienced in engineering and manufacturing of analytical systems and analyzer houses. We are familiar with communication networks, well trained in service and maintenance and familiar with many industrial processes and industries. Thus, Siemens Analytical Products and Solutions owns a unique blend of overall analytical expertise and experience.

- Global presence
 With our strategically located centers of competence in Germany, USA, Singapore, and Dubai, we are globally present and acquainted with all respective local and regional requirements, codes and standards. All centers are networked together.

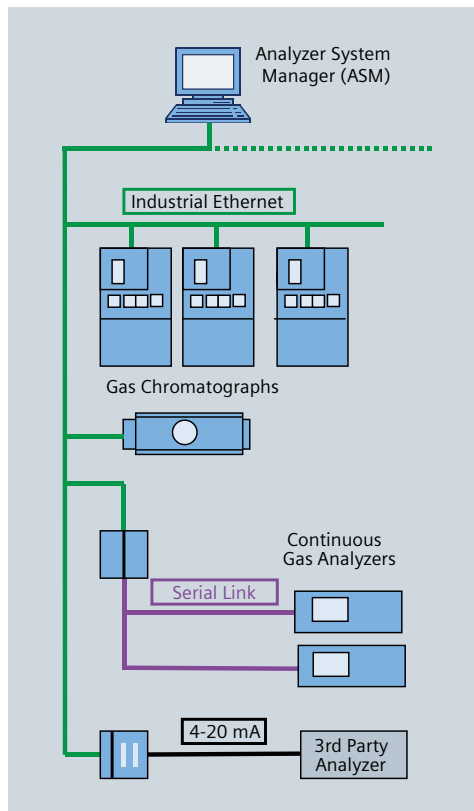

Fig. 14: Communication technologies



Fig. 16: Portfolio of services

Siemens Analytical Products and Solutions at a glance (continued)

Our Services ...

Service portfolio

Our wide portfolio of services is segmented into Consulting, Support and Service (fig. 16 to 17). It comprises really all measures, actions and advises that may be required by our clients throughout the entire lifecycle of their plant. It ranges from site survey to installation check, from instruction of plant personnel to spare part stock management and from FEED for Process Analytics (see below) to internet-based service Hotline.

Our service and support portfolio (including third-party equipment) comprises for example:

- Installation check
- Functionality tests
- Site acceptance test
- Instruction of plant personnel on site
- Preventive maintenance
- On site repair
- Remote fault clearance
- Spare part stock evaluation
- Spare part management
- Professional training center
- Process optimization
- Internet-based hotline
- FEED for Process Analytics
- Technical consulting

FEED for Process Analytics

Front End Engineering and Design (FEED) is part of the planning and engineering phase of a plant construction or modification project and is done after conceptual business planning and prior to detail design. During the FEED phase, best opportunities exist for costs and time savings for the project, as during this phase most of the entire costs are defined and changes have least impact to the project. Siemens Analytical Products and Solutions holds a unique blend of expertise in analytical technologies, applications and in providing complete analytical solutions to many industries. Based on its expertise in analytical technology, application and engineering, Siemens Analytical Products and Solutions offer a wide scope of FEED services focused on analyzing principles, sampling technologies, application solutions as well as communication system and given

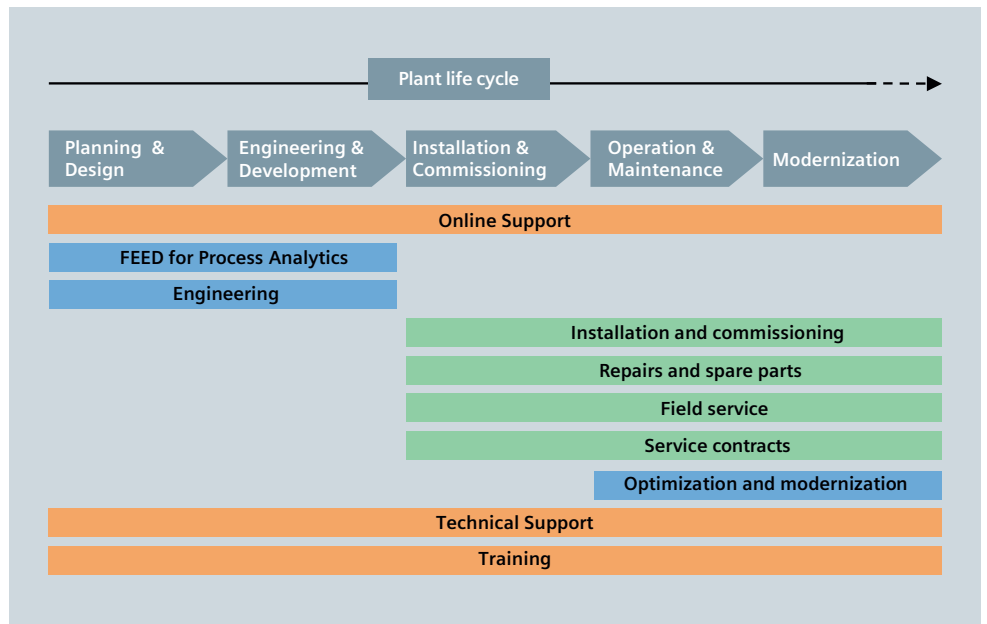

Fig. 17: Portfolio of services provided by Siemens Process Analytics

standards (all related to analytics) to support our clients in maximizing performance and efficiency of their projects.

Whether you are plant operators or belong to an EPC Contractor you will benefit in various ways from FEED for Process Analytics by Siemens:

- Analytics and industry know how available, right from the beginning of the project
- Superior analyzer system performance with high availability
- Established studies, that lead to realistic investment decisions
- Fast and clear design of the analyzer system specifications, drawings and documentation
- Little project management and coordination effort, due to one responsible contact person and less time involvement
- Additional expertise on demand, without having the costs, the effort and the risks of building up the capacities
- Lowest possible Total Costs of Ownership (TCO) along the lifecycle regarding investment costs, consumptions, utilities supply and maintenance

For more information, please contact:

Siemens Industry, Inc.
5980 West Sam Houston Parkway North
Suite 500
Houston, TX 77041
Phone: 713-939-7400
Email: ProcessAnalyticsSales.industry@siemens.com

Siemens Industry, Inc.
3333 Old Milton Parkway
Alpharetta, GA 30005

1-800-241-4453
info.us@siemens.com

Subject to change without prior notice
Order No.: PIACS-00008-0515
Printed in USA
© 2015 Siemens Industry, Inc.

usa.siemens.com/analyticalproducts

The information provided in this flyer contains merely general descriptions or characteristics of performance which in case of actual use do not always apply as described or which may change as a result of further development of the products. An obligation to provide the respective characteristics shall only exist if expressly agreed in the terms of the contract.

All product designations may be trademarks or product names of Siemens AG or supplier companies whose use by third parties for their own purposes could violate the rights of the owners.