

Overview

The OXYMAT 64 gas analyzer is used for the trace measurement of oxygen.

Benefits

- High linearity
- Compact design
- Open interface architecture (RS 485, RS 232, PROFIBUS)
- SIPROM GA network for maintenance and service information (option)

Application

Production of technical gases

- Measurements in N₂ and CO₂

Welding

- Measurements in protective gases during welding of highly alloyed steels, titanium, etc.

Systems for air separation

- Measurements in N₂ and in inert gases (e.g. Ne, Ar)
Measurements in CO₂

Food production

- Measurement in CO₂ (e.g. breweries)

Electronics industry

- Low-pressure version with pump

Flow soldering systems

Design

- 19" rack unit with 4 HU for installation
 - In hinged frame
 - In cabinets with or without telescope rails
- Front plate can be swung down for servicing purposes (laptop connection)
- Connections for sample gas
 - Input: Clamping ring connection for a pipe diameter of 6 mm or 1/4"
 - Output: Pipe connection with diameter 6 mm or 1/4"
- High-pressure and low-pressure versions
- Catalytically active and inactive cell

Display and control panel

- Large LCD field for simultaneous display of
 - Measured value
 - Status bar
 - Measuring ranges
- Contrast of the LCD field adjustable via the menu
- Permanent LED backlighting
- Washable membrane keyboard with five softkeys
- Five-digit measured-value display (decimal point counts as one digit)
- Menu-driven operation for parameterization, configuration, test functions, adjustment
- User help in plain text
- Graphic display of concentration trend; programmable time intervals
- Bilingual operating software German/English, English/Spanish, French/English, Spanish/English, Italian/English
- Switchover from ppm/vpm measuring range to % measuring range

Input and outputs

- One analog output per medium (from 0, 2, 4 to 20 mA; NAMUR parameterizable)
- Six digital inputs freely configurable (e.g. for measurement range switchover, processing of external signals from sample preparation)
- Six relay outputs freely configurable (failure, maintenance demanded, maintenance switch, threshold alarm, external magnetic valves)
- Two analog inputs configurable (e.g. correction of cross-interference, external pressure sensor)
- Expansion by eight additional digital inputs and eight additional relay outputs for autocalibration with up to four calibration gases

Communication

RS 485 present in basic unit (connection from the rear).

Options

- RS 485/RS 232 converter
- RS 485/Ethernet converter
- RS 485/USB converter
- Connection to networks via PROFIBUS DP/PA interface
- SIPROM GA software as the service and maintenance tool

Extractive continuous process gas analysis

Series 6

OXYMAT 64

General information

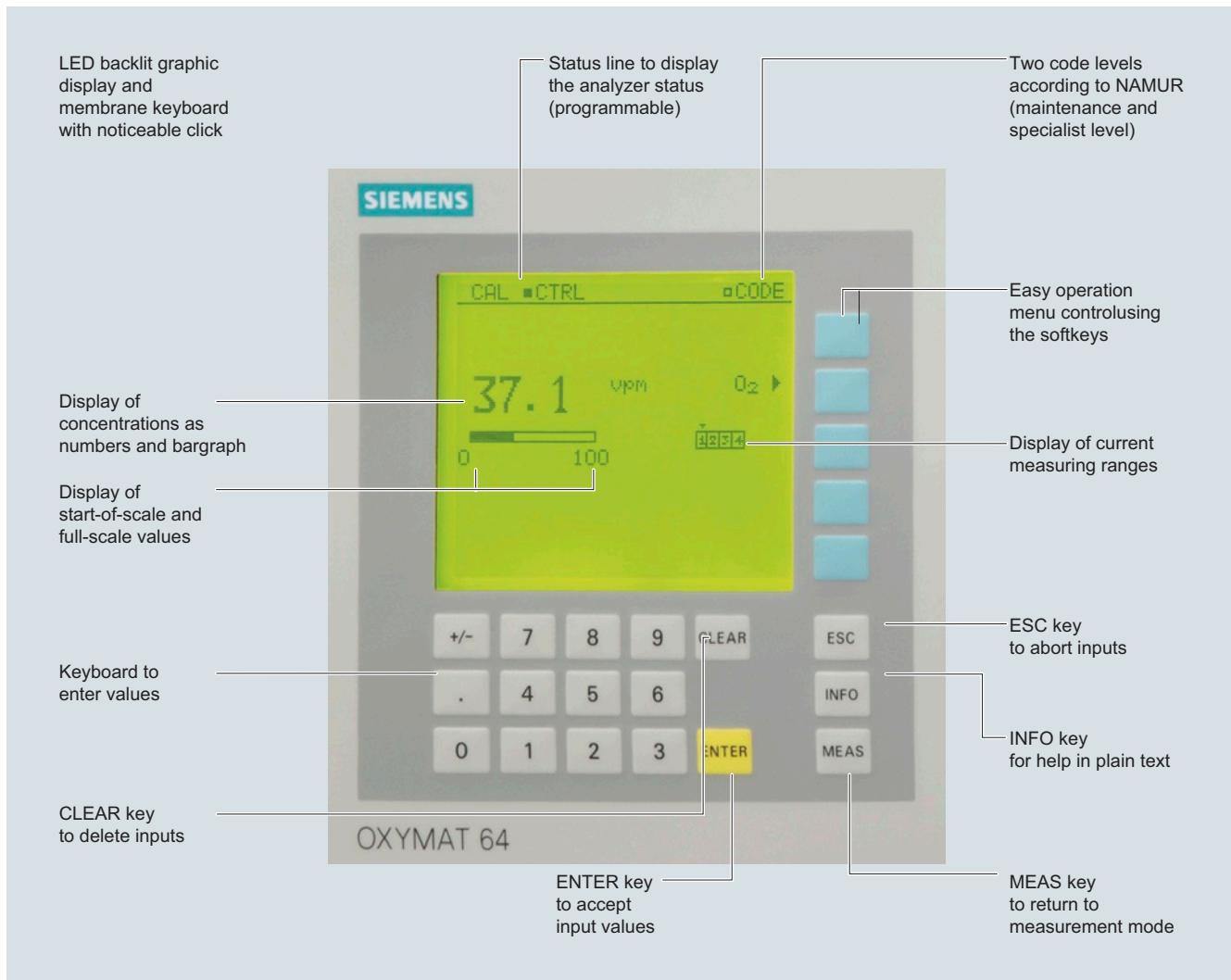

OXYMAT 64, membrane keyboard and graphic display

Designs – Parts wetted by sample gas, standard

| Gas path | | 19" rack unit |
|------------------------|-----------------------|----------------------------------|
| Sample gas path | Bushing | Stainless steel, mat. no. 1.4571 |
| | Pipe inlet | Stainless steel |
| | O ₂ sensor | ZrO ₂ ceramic |
| | Bypass line | FPM (Viton) |
| | Connection pieces | PTFE (Teflon) |
| Pressure sensor | Enclosure | Polycarbonate |
| | Membrane | SiO ₄ |
| | Sensor adapter | Aluminum |
| | Bypass restrictor | Stainless steel, mat. no. 1.4571 |
| Flow indicator | Measurement pipe | Duran glass |
| | Variable area | Duran glass, black |
| | Suspension boundary | PTFE (Teflon) |
| | Angle pieces | FKM (Viton) |
| Pressure switch | Enclosure | Polycarbonate |
| | Diaphragm | NBR |

Gas path (high-pressure version)**Legend for the gas path figure**

| | | | |
|---|--|----|------------------------|
| 1 | Sample gas inlet; inlet pressure - Without internal pressure regulator: 2 000 hPa (abs.), regulated - With internal pressure regulator: 2 000 ... 6 000 hPa (abs.) | 6 | Bypass restrictor |
| 2 | Sample gas outlet; sample gas flows off free of dynamic pressure | 7 | Pressure switch |
| 3 | Pressure regulator (order version) | 8 | Flow measuring tube |
| 4 | O ₂ sensor | 9 | Purging gas connection |
| 5 | Pressure sensor | 10 | Restrictor |
| | | 11 | Sample gas restrictor |

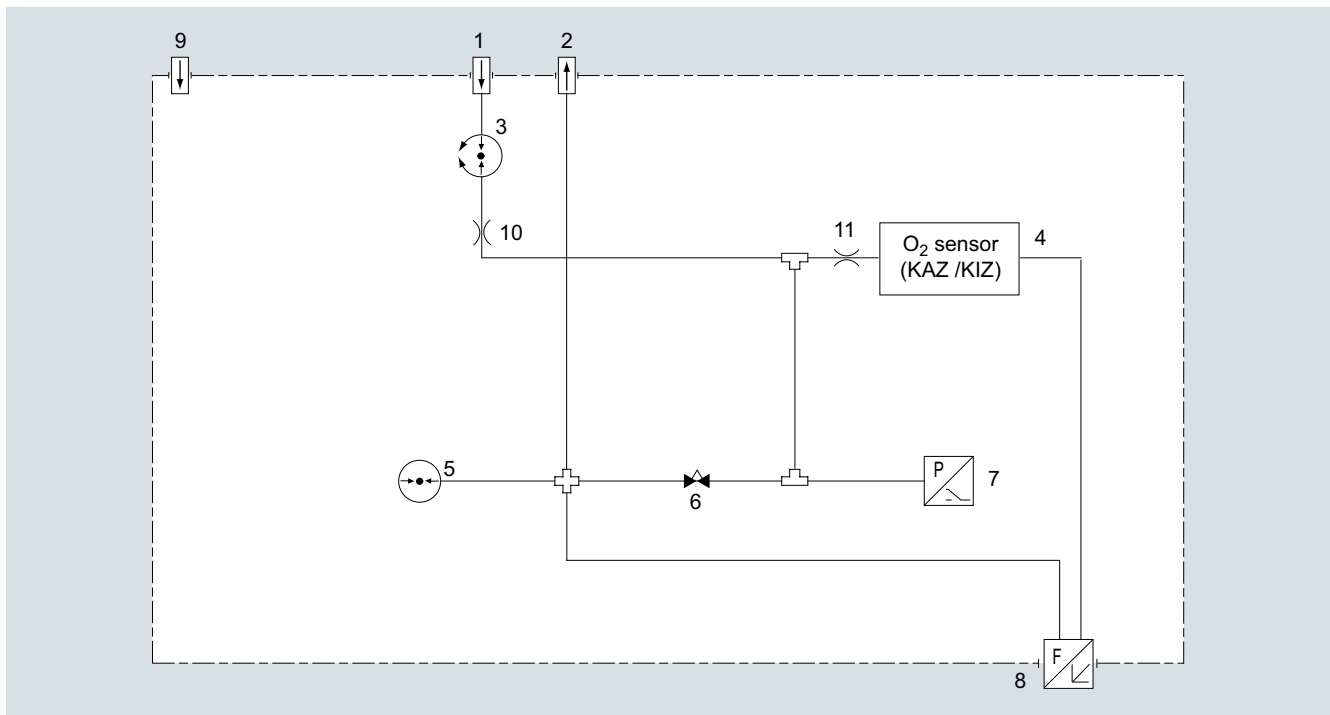

Gas path OXYMAT 64, high-pressure version

The sample gas pressure (2 000 to 6 000 hPa) is regulated by the pressure regulator (3) at approx. 2 000 hPa or is provided by the operator with 2 000 hPa. This pressure is applied at the restrictor (10). The restrictor (10) reduces the pressure such that a sample gas flow of 15 to 30 l/h is created. This flow is subdivided via the sample gas restrictor (11) and the adjustable bypass restrictor (6) such that there is a sample gas flow of 7.5 l/h through the sensor.

If the sample gas can flow off into the atmosphere unhampered, the sample gas pressure corresponds to the atmospheric pressure. If the sample gas flows off via an exhaust gas line, it works like a flow resistance. If the resulting dynamic pressure exceeds 100 hPa (rel.), a maintenance demanded is output.

Extractive continuous process gas analysis

Series 6

OXYMAT 64

General information

Gas path (low pressure)

Legend for the gas path figure

| | | | |
|---|--|---|------------------------|
| 1 | Sample gas inlet; flow 125 ml/min (7.5 l/h) | 5 | Pressure switch |
| 2 | Sample gas outlet; sample gas flows off free of dynamic pressure | 6 | Flow measuring tube |
| 3 | O ₂ sensor | 7 | Purging gas connection |
| 4 | Pressure sensor | 8 | Restrictor |

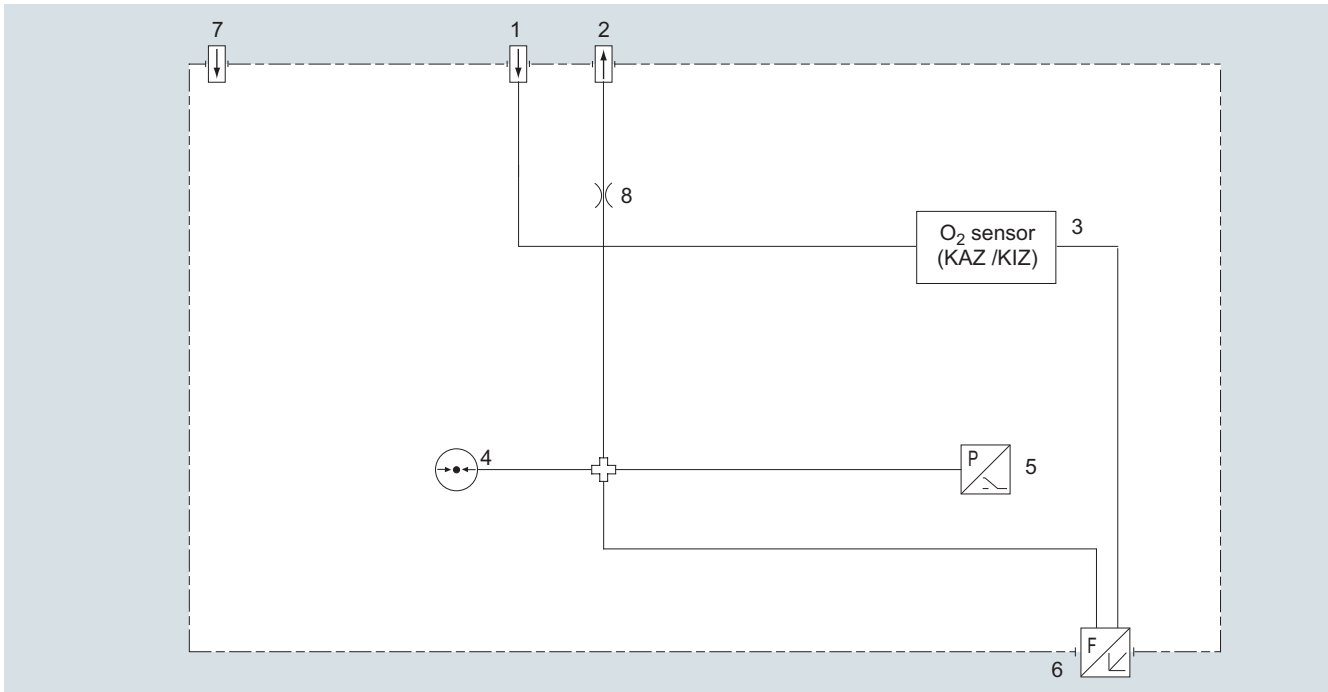

Gas path OXYMAT 64, low-pressure version

With the low-pressure version, the sample gas flow must be set externally to 125 ml/min. With a built-in pressure switch, the sample gas pressure is approx. 30 hPa above the current atmospheric pressure since the sample gas flows off via a restrictor. If the resulting dynamic pressure exceeds 100 hPa (rel.), a maintenance demanded is output. In order to reduce the 90% time, we recommend installation of a bypass upstream of the gas inlet which then provides a faster exchange of gas. This is particularly important with long sample gas lines between the gas sampling point and the analyzer. Please make absolutely sure that the flow in the OXYMAT 64 does not exceed 125 ml/min.

Gas path (low pressure with integrated sample gas pump)**Legend for the gas path figure**

| | | | |
|---|--|---|------------------------|
| 1 | Sample gas inlet | 6 | Flow measuring tube |
| 2 | Sample gas outlet; sample gas flows off free of dynamic pressure | 7 | Sample gas pump |
| 3 | O ₂ sensor | 8 | Restrictor |
| 4 | Pressure sensor | 9 | Purging gas connection |
| 5 | Needle valve | | |

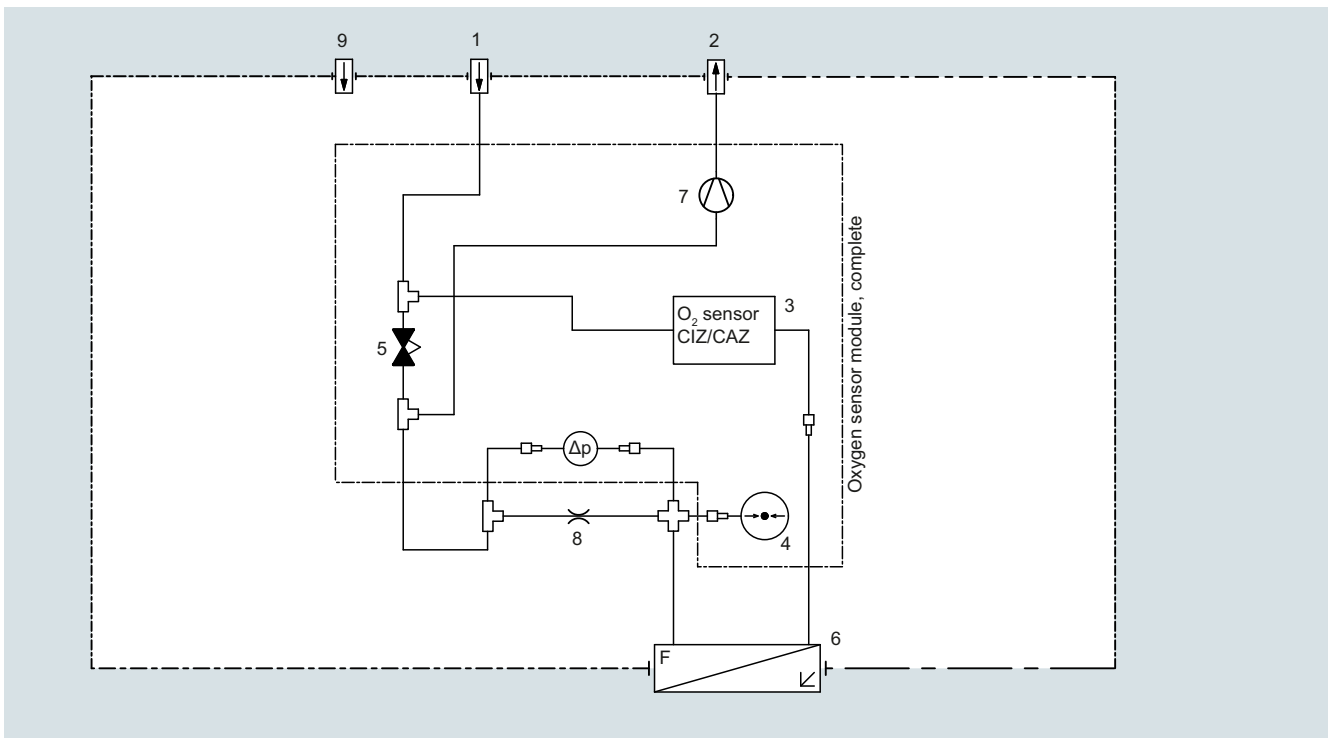
**Low-pressure version with integral sample gas pump**

The device version "OXYMAT 64 low-pressure with pump" is equipped with a sample gas pump which automatically provides a constant sample gas flow of 125 ml/min through the sensor. By means of an internal bypass, the total flow of sample gas through the analyzer is increased to approx. 0.4 l/min. This measure significantly improves the analyzer's response time.

Extractive continuous process gas analysis

Series 6

OXYMAT 64

General information

Function

The measuring cell consists of a cylindrical (pipe-shaped) ZrO_2 membrane. The sample gas (low O_2 content) flows at a constant rate through the inside of the membrane, which is regulated at $650\text{ }^\circ\text{C}$. The exterior of the sensor is exposed to the ambient air (approx. 21 % O_2).

Both sides of the ZrO_2 membrane are coated with thin platinum films that act as electrodes. This forms a solid, electrochemical cell. The amount of oxygen atoms ionized depends on the oxygen concentration at the electrodes.

The differences in concentration at each side means that a differential partial pressure prevails. Since ZrO_2 conducts ions at $650\text{ }^\circ\text{C}$, ionic migration takes place in the direction of the lower partial pressure.

An oxygen gradient arises across the width of the ZrO_2 membrane, which, according to equation (1), results in an electrical potential difference between the platinum electrodes.

Defects in the crystal lattice, caused by contamination of the ZrO_2 material with Y_2O_3 and/or CaO (introduced originally to prevent cracks forming in ceramic material) make it easier for O_2 ions to diffuse in the ZrO_2 grid.

Catalytically active ZrO_2 sensor (CAZ)

The electrode material is made of platinum (Pt). This type of sensor has a higher cross-sensitivity when flammable accompanying gas components are present.

Catalytically inactive ZrO_2 sensor (CIZ)

The catalytically inactive sensor has the same general design as the CAZ. The contacts and electrode surface inside the pipe are made of a specially developed material which largely prevents catalytic oxidation except of H_2 , CO and CH_4 .

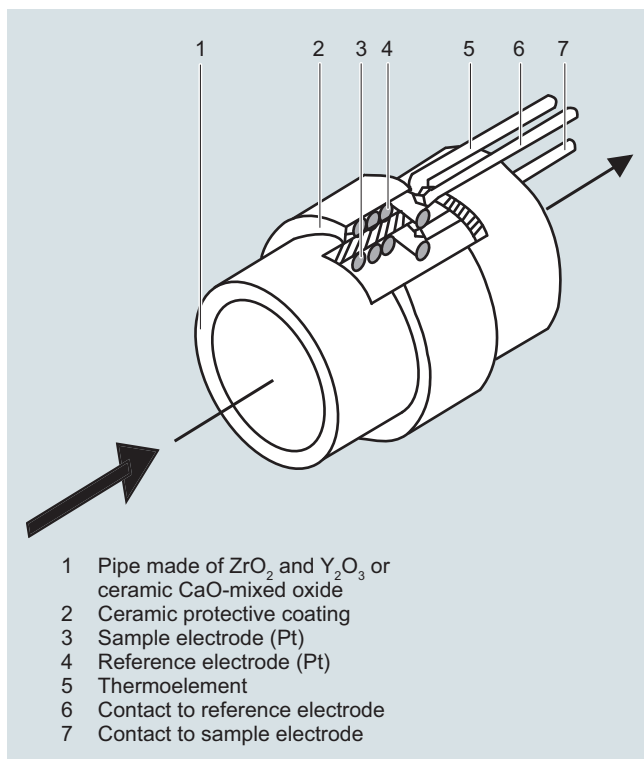

OXYMAT 64, principle of operation

Measuring effect

$$U = U_A + RT/4F (\ln [O_{2,air}] - \ln [O_2]) \text{ (equation 1)}$$

U measuring effect

U_A asymmetric voltage (voltage, at $[O_2] = [O_{2,air}]$)

T ceramic temperature

$[O_{2,air}]$ O_2 concentration in the air

$[O_2]$ O_2 concentration in sample gas

Note

The sample gas must be fed into the analyzer free of dust. Condensation should be avoided. Therefore, gas modified for the measuring tasks is necessary in most application cases.

Calibration

Calibration of the calibration point is carried out as with the other analyzers of Series 6 after a maximum of 14 days by connecting the calibration gas O_2 in residual N_2 at concentrations of approx. 60 to 90% of the master measuring range.

Contrary to the other analyzers of Series 6, the zero point calibration cannot be carried out using pure nitrogen, but with a "small" concentration of oxygen in nitrogen appropriate to the selected measuring range (e.g.: Measuring range 0 to 10 vpm; calibration gas approx. 2 vpm O_2 in residual N_2).

Essential characteristics

- Four measurement ranges freely parameterizable, all measurement ranges linear
- Galvanically isolated measurement value output 0/2/4 through 20 mA (also inverted) and as per NAMUR
- Autoranging selectable; possibility of remote switching
- Storage of measured values possible during adjustments
- Wide range of selectable time constants (static/dynamic noise suppression); i.e. the response time of the device can be adapted to the respective measuring task
- Easy handling thanks to menu-driven operation
- Low long-term drift
- Two control levels with their own authorization codes for the prevention of accidental and unauthorized operator interventions
- Automatic measuring range calibration can be configured
- Operation based on the NAMUR recommendation
- Monitoring of the sample gas (via pressure switch)
- Customer-specific analyzer options such as:
 - Customer acceptance
 - TAG labels
 - Drift recording
- Simple handling using a numerical membrane keyboard and operator prompting
- Smallest span 0 to 10 vpm O_2
- Largest span 0 to 100 % (testing with ambient air)
- Internal pressure sensor for correction of the influence of sample gas pressure fluctuations

Influence of interfering gasCatalytically active sensor (CAZ)

Very large cross-interference of all combustible accompanying gases. Thus not suitable for use with combustible accompanying gases!

Catalytically inactive sensor (CIZ)

There is only a slight cross-interference in the case of accompanying gases with a concentration in the range of the O₂ concentration. H₂, CO and CH₄ still have a noticeable effect in the case of flammable accompanying gas components.

| Measured component / interfering gas | Diagonal gas offset |
|--|---------------------|
| 78 vpm O ₂ /140 vpm CO | -6.1 vpm |
| 10 vpm O ₂ /10 vpm CO | -0.6 vpm |
| 74 vpm O ₂ / 25 vpm CH ₄ | -0.3 vpm |
| 25 vpm O ₂ / 357 vpm CH ₄ | -1.1 vpm |
| 25 vpm O ₂ / 70 vpm H ₂ | -3 vpm |
| 5 vpm O ₂ / 9.6 vpm H ₂ | -0.55 vpm |
| 170 vpm O ₂ / 930 vpm C ₂ H ₄ | -118 vpm |

Examples of typical diagonal gas offsets on a catalytically inactive sensor

The listed deviations depend on the exemplar and can deviate up to ± 0.2 vpm. The actual deviation must be determined individually or the error will be eliminated through a corresponding calibration measure (displacement of the diagonal gas offset).

Extractive continuous process gas analysis

Series 6

OXYMAT 64

19" rack unit

1

Technical specifications

General

| | |
|---|---|
| Measurement ranges | 4, internally and externally switchable; automatic measuring range switchover also possible |
| Smallest possible span (relating to sample gas pressure 1 000 hPa absolute, 0.5 l/min sample gas flow, and 25 °C ambient temperature) | 0 ... 10 vpm O ₂ |
| Largest possible measuring span | 0 ... 100% |
| Operating position | Front wall vertical |
| Conformity | CE mark in accordance with EN 50081-1, EN 50082-2 and RoHS |

Design, enclosure

| | |
|----------------------|----------------------------|
| Degree of protection | IP20 according to EN 60529 |
| Weight | Approx. 11 kg |

Electrical characteristics

| | |
|---|--|
| EMC interference immunity (electromagnetic compatibility) | In accordance with standard requirements of NAMUR NE21 (08/98) and EN 61326 |
| Electrical safety | In accordance with EN 61010-1, overvoltage category II |
| Power supply | 100 ... 120 V AC (nominal range of use 90 ... 132 V), 48 ... 63 Hz or 200 ... 240 V AC (nominal range of use 180 ... 264 V), 48 ... 63 Hz |
| Power consumption | Approx. 37 VA |
| Fuse values | 100 ... 120 V: 1.0T/250 200 ... 240 V: 0.63T/250 |

Gas inlet conditions

| | |
|---|--|
| Sample gas flow | 7.5 l/h |
| <ul style="list-style-type: none"> through the sensor Overall consumption | 15 ... 30 l/h |
| Permissible sample gas pressure | 2 000 hPa (abs.) |
| <ul style="list-style-type: none"> Without internal pressure regulator With internal pressure regulator | 2 000 ... 6 000 hPa (abs.) |
| Sample gas temperature | Min. 0 ... max. 50 °C, but above the dew point |
| Sample gas humidity | < 1% relative humidity |

Dynamic response

| | |
|--|--|
| Warm-up period | At room temperature < 30 min (the technical specification will be met after 2 hours) |
| Damping (electrical time constant) | 0 ... 100 s, configurable |
| Dead time (high-pressure version) (purging time of the gas path in the unit at 125 ml/min) | 10 ... 30 s |
| Dead time (low-pressure version without pump) | < 5 s |
| Dead time (low-pressure version with pump) | < 10 s |
| Time for device-internal signal processing | < 1 s |

Pressure correction range

| | |
|--------------------------|--------------------------|
| Pressure sensor internal | 800 ... 1 100 hPa (abs.) |
|--------------------------|--------------------------|

Measuring response

| | |
|---------------------------|--|
| | Based on sample gas pressure 1 013 hPa absolute, 7.5 l/min sample gas flow and 25 °C ambient temperature |
| Output signal fluctuation | < ± 1% of the smallest possible measuring range according to rating plate, with electronic damping constant of 1 s |
| Zero point drift | < ± 1% of the current span/month |
| Measured-value drift | < ± 1% of the current span/month |
| Repeatability | < 3% of the current measuring span |
| Detection limit | 1% of current measuring range, < 0.1 vpm in measuring range 0 ... 10 vpm |
| Linearity error | < 2% of the current measuring span |

Influencing variables

| | |
|--|--|
| | Based on sample gas pressure 1 013 hPa absolute, 7.5 l/min sample gas flow and 25 °C ambient temperature |
| Ambient temperature | < 2%/10 K referred to current measuring span |
| Sample gas pressure only possible if the sample gas can flow out into the ambient air | <ul style="list-style-type: none"> With deactivated pressure compensation: < 1% of current span/1% pressure change With activated pressure compensation: < 0.2% of current span / 1% pressure change |
| Residual gases, deviation from zero point | Only gases with non-combustible residual gas components can be introduced |
| <ul style="list-style-type: none"> Catalytically active sensor (CAZ) Catalytically inactive sensor (CIZ) | Residual gas concentration of 10 vpm H ₂ ; CO and CH ₄ have a lower cross-interference; higher HCs are negligible |
| Sample gas flow | < 2% of the smallest possible span with a change in flow of 10 ml/min |
| Power supply | < 0.1% of the current measuring range with rated voltage ± 10% |

Electrical inputs and outputs

| | |
|------------------|--|
| Analog output | 0/2/4 ... 20 mA, 4 ... 20 mA (NAMUR), isolated; max. load 750 Ω |
| Relay outputs | 6, with changeover contacts, freely parameterizable, e.g. for measuring range identification; load: 24 V AC/DC/1 A, isolated |
| Analog inputs | 2, dimensioned for 0/2/4 ... 20 mA for external pressure sensor and correction of influence of residual gas (correction of cross-interference) |
| Digital inputs | 6, designed for 24 V, isolated, freely parameterizable, e.g. for measurement range switchover |
| Serial interface | RS 485 |
| Options | AUTOCAL function each with 8 additional digital inputs and relay outputs, also with PROFIBUS PA or PROFIBUS DP |

Climatic conditions

| | |
|---------------------------------|--|
| Permissible ambient temperature | -40 ... +70 °C during storage and transportation, 5 ... 45 °C in operation |
| Permissible humidity | < 90% relative humidity as annual average, during storage and transportation (must not fall below dew point) |

| Selection and ordering data | Article No. | |
|--|-----------------------|--------------------|
| OXYMAT 64 gas analyzer 19" rack unit for installation in cabinets | 7MB2041- 1 - A | Cannot be combined |
| Click on the Article No. for the online configuration in the PIA Life Cycle Portal. | | |
| Sensor ZrO ₂ : Catalytically active cell (CAC) ZrO ₂ : Catalytically inactive cell (CIC) ZrO ₂ : Catalytically active cell (CAC); with differential pressure sensor ZrO ₂ : Catalytically inactive cell (CIC); with differential pressure sensor | 0 1 2 3 | 0 1 2 3 |
| Sample gas pressure High pressure, without pressure regulator 2 000 hPa (abs.) High pressure, with pressure regulator 2 000 ... 6 000 hPa (abs.) Low pressure, with pump Atmosphere Low pressure, without suction pump Atmosphere | A B C D | C A B D |
| Gas connection Input Clamping ring connection 6 mm Output Fittings 6 mm Input Clamping ring connection ¼" Output Fitting ¼" | A B | |
| Add-on electronics Without AUTOCAL function • With 8 additional digital inputs/outputs • With 8 additional digital inputs/outputs and PROFIBUS PA interface • With 8 additional digital inputs/outputs and PROFIBUS DP interface | 0 1 6 7 | |
| Power supply 100 to 120 V AC, 48 to 63 Hz 200 to 240 V AC, 48 to 63 Hz | 0 1 | |
| Explosion protection Without | A | |
| Language German English French Spanish Italian | 0 1 2 3 4 | |
| Additional versions | Order code | |
| Add "-Z" to Article No. and specify Order code | | |
| Telescopic rails (2 units) | A31 | |
| TAG labels (specific lettering based on customer information) | B03 | |
| Clean for O ₂ service (specially cleaned gas path) | Y02 | |
| Measuring range indication in plain text, if different from the standard setting | Y11 | |
| Special setting (only in conjunction with an application no., e.g. extended measuring range) | Y12 | |
| Extended special setting (only in conjunction with an application no., e.g. determination of cross-interferences) | Y13 | |
| Accessories | Article No. | |
| RS 485/Ethernet converter | A5E00852383 | |
| RS 485/RS 232 converter | C79451-Z1589-U1 | |
| RS 485/USB converter | A5E00852382 | |
| AUTOCAL function each with 8 digital inputs/outputs | C79451-A3480-D511 | |
| AUTOCAL function 8 digital inputs/outputs each and PROFIBUS PA | A5E00057307 | |
| AUTOCAL function 8 digital inputs/outputs each and PROFIBUS DP | A5E00057312 | |
| Set of Torx screwdrivers | A5E34821625 | |

Extractive continuous process gas analysis

Series 6

OXYMAT 64

19" rack unit

1

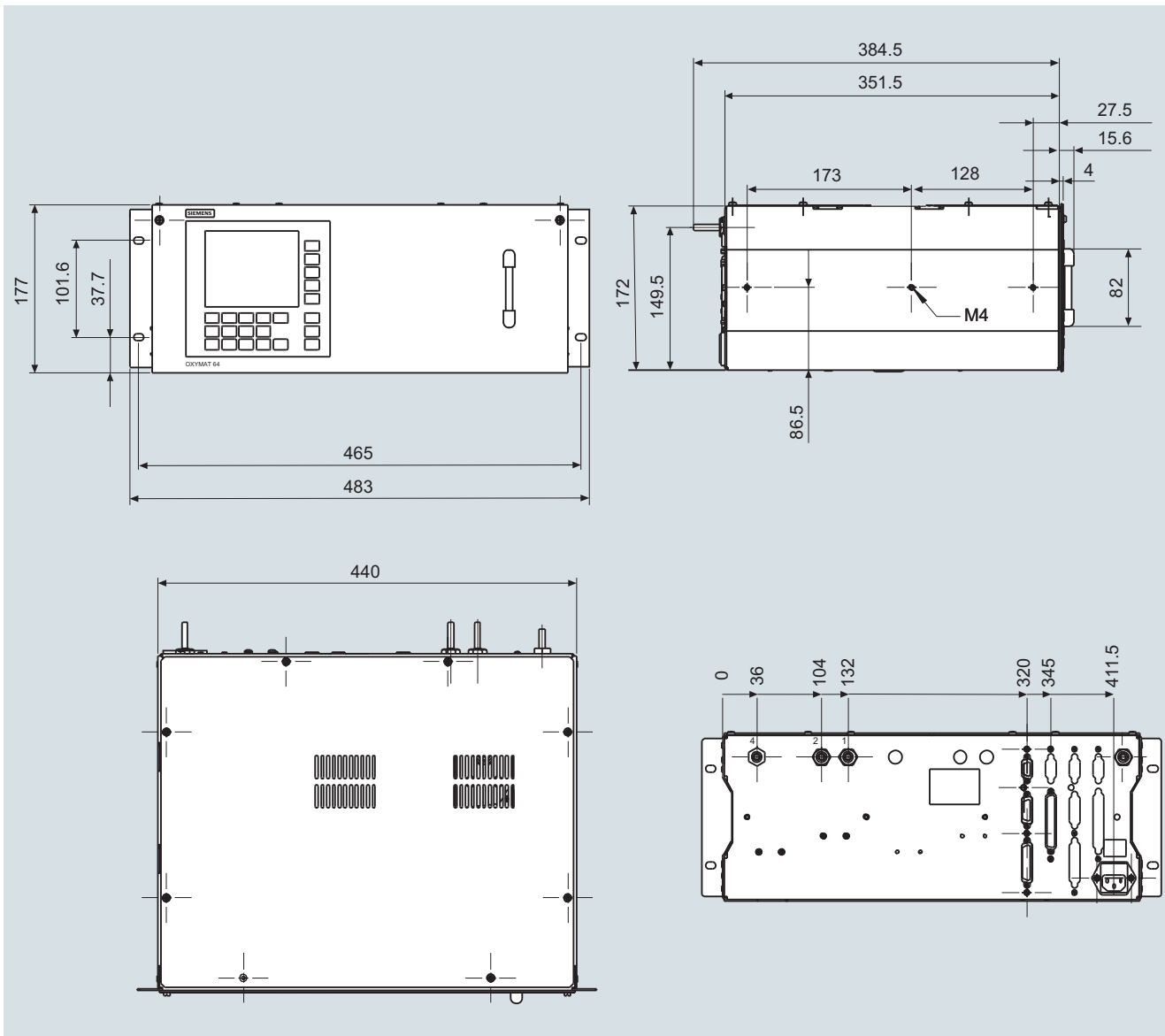
Dimensional drawings

OXYMAT 64, 19" rack unit, size in mm

Circuit diagrams

Pin assignment (electrical connections)

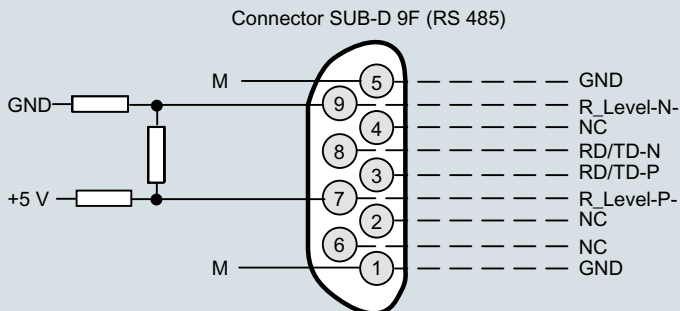

It is possible to connect bus terminating resistors to pins 7 and 9.

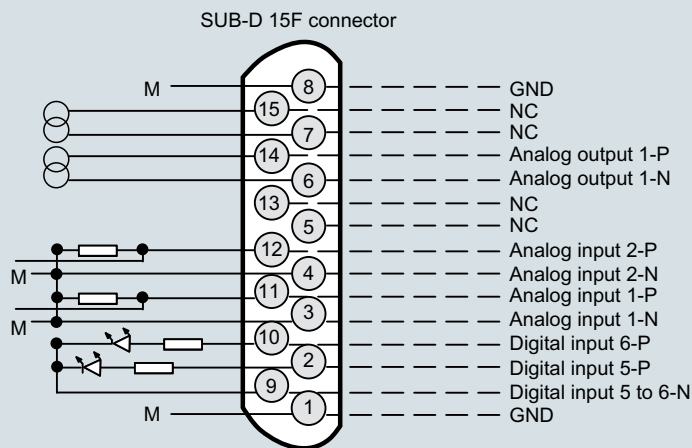

Analog outputs isolated (also from each other), $R_L \leq 750 \Omega$

Pressure correction } Non-isolated analog inputs,
 Pressure correction } 0 ... 20 mA/500 Ω or
 Correction of cross-interference } 0 ... 10 V (low resistance)
 Correction of cross-interference }

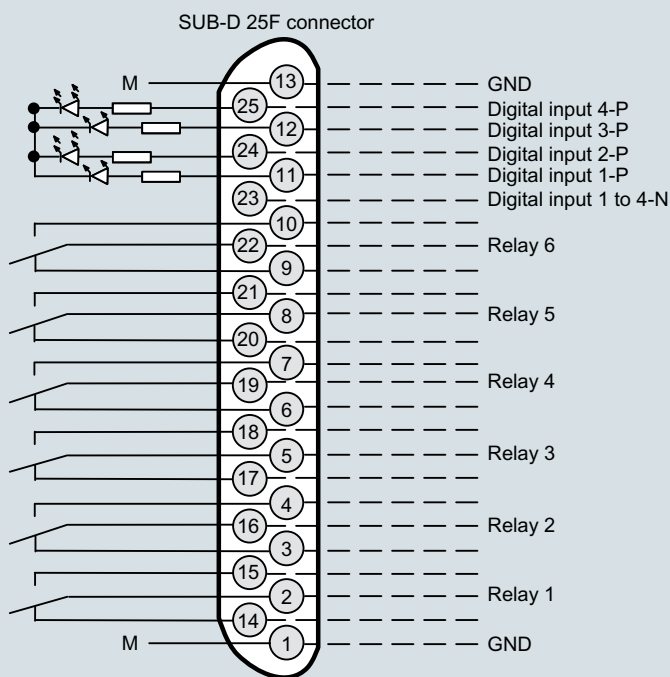

Isolated via optocoupler
 "0" = 0 V (0 ... 4.5 V)
 "1" = 24 V (13 ... 33 V)

Contact load
 max. 24 V/1 A, AC/DC
 The relay is current-free for the relay contact position shown

Note:
 All cables to the connectors or terminal blocks must be shielded and rest against the enclosure potential.

OXYMAT 64, 19" rack unit, pin assignment

Extractive continuous process gas analysis

Series 6
OXYMAT 64

19" rack unit

1

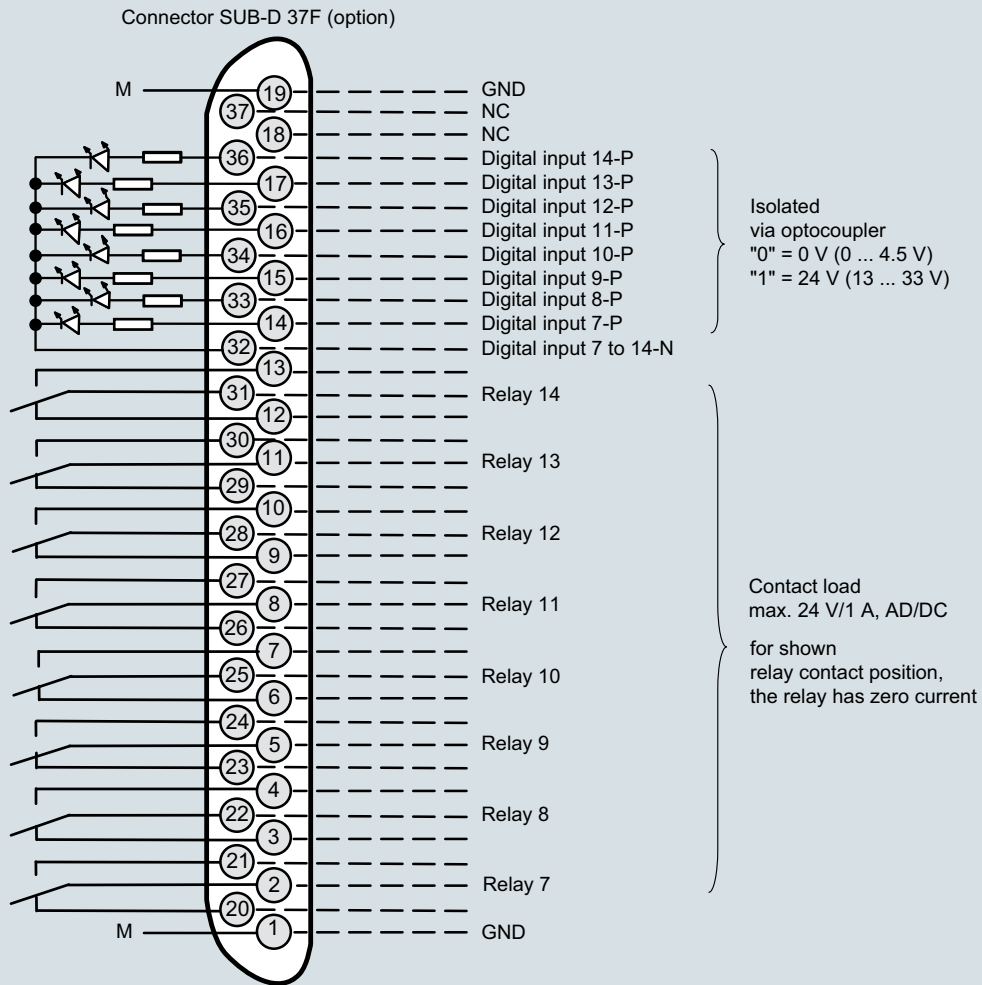

Connector SUB-D 9F-X90
PROFIBUS DP

Optional

Connector SUB-D 9M-X90
PROFIBUS PA

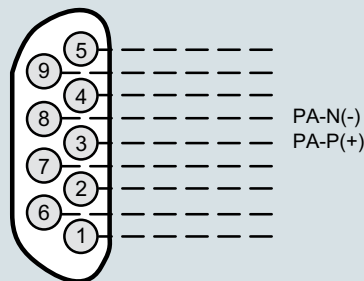
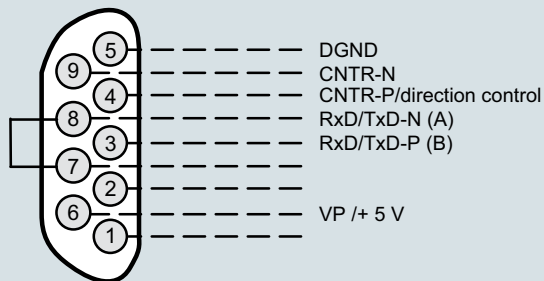

Note:
All cables to the connectors or terminal blocks must be shielded and rest against the enclosure potential.

OXYMAT 64, 19" rack unit, pin assignment of the AUTOCAL plate and PROFIBUS plug

Gas connections and pin assignment

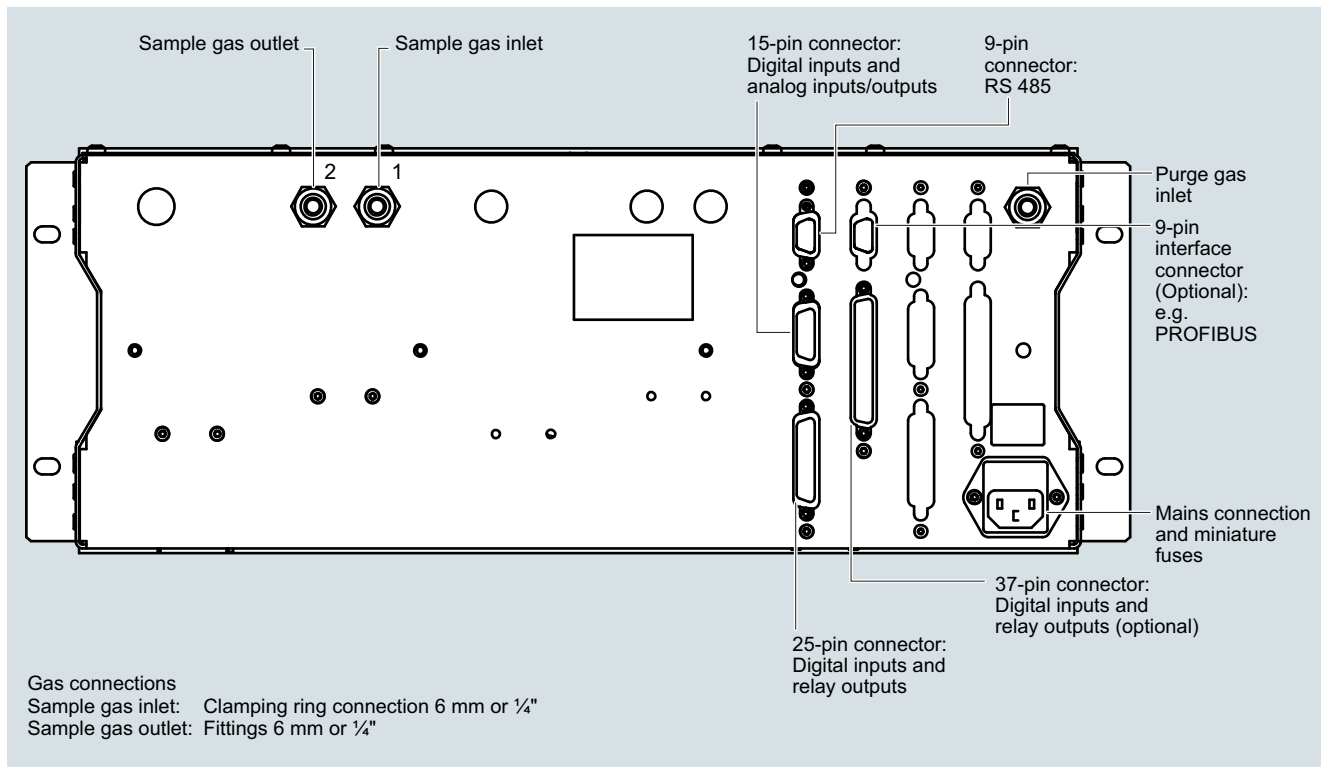

OXYMAT 64, 19" rack unit, gas connections and electrical connections

Extractive continuous process gas analysis

Series 6

OXYMAT 64

Documentation, suggestions for spare parts

1

Selection and ordering data

| Operating instructions | Article No. |
|---|-------------|
| Gas analyzers of Series 6 and ULTRAMAT 23 Schnittstelle/Interface PROFIBUS DP/PA • German and English | A5E00054148 |

More information

The complete documentation is available in various languages for downloading free of charge:
<http://www.siemens.com/processanalytics/documentation>

Selection and ordering data

| Description | 7MB2041 | 2 years (quantity) | 5 years (quantity) | Article No. |
|--|---------|-----------------------|-----------------------|-------------------|
| Pressure regulator as spare part | x | – | 1 | A5E01008972 |
| Flowmeter | x | – | 1 | A5E01061561 |
| Adapter plate, LC display/keypad | x | 1 | 1 | C79451-A3474-B605 |
| LC display | x | – | 1 | A5E31474846 |
| Connector filter | x | – | 1 | W75041-E5602-K2 |
| Fuse, T 0.63 A, line voltage 200 ... 240 V | x | 2 | 4 | W79054-L1010-T630 |
| Fuse, T 1 A, line voltage 100 ... 120 V | x | 2 | 4 | W79054-L1011-T100 |