

Instructions

E87010-A0076-T003-A1-75XX

August, 2012
Supersedes Issue of
May, 2000

Contact Kit, Innova Controllers
Size 3, 3^{1/2}, & 4
Class 14, 22, 30, 40, & 43
Cat. No. 75HF14, 75IF14, & 75JG14

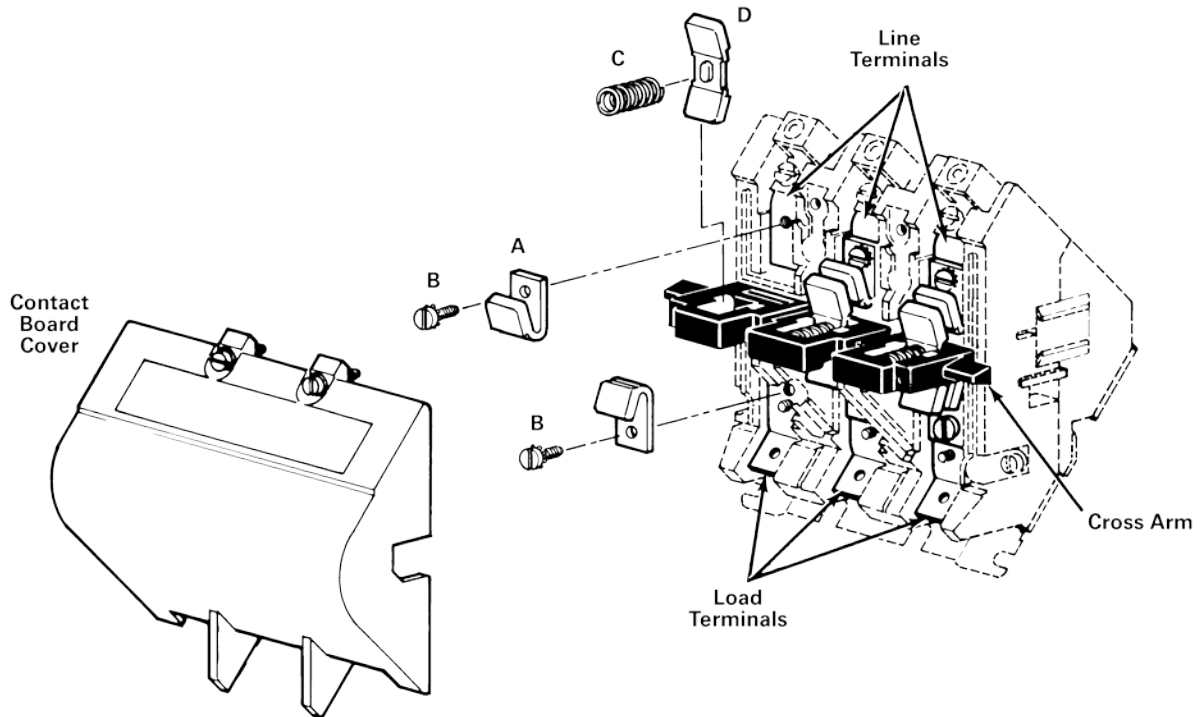

KIT DATA

Use with sizes 3, 3^{1/2}, and 4 Innova series controllers. Use kit catalog number 75HF14 for size 3 controllers, 75IF14 for size 3^{1/2} controllers and 75JG14 for size 4 controllers.

Rating: The contact assumes the rating of the control on which the contact is mounted.

Contents of kits, catalog numbers 75HF14, 75IF14, and 75JG14:

- 2 **A** stationary contacts, one for the line terminal and one for the load terminal
- 2 **B** mounting screws
- 1 **C** spring
- 1 **D** movable contact bar

of the controller is recommended to assure proper contact mating.

1. Remove the contact board cover from the controller.
2. Compress the movable contact spring in the cross arm and remove the spring. Remove the worn movable contact bar from the cross arm. Discard the spring and bar.
3. Remove the worn stationary contacts from the line and load terminals. Discard the contacts.
4. Secure the stationary contacts **A** to the line and load terminals with mounting screws **B**. Tighten each screw to 30 inch-pounds minimum torque.
5. Install the movable contact bar **D** in the cross arm. Compress spring **C** and, while holding the movable contact bar toward the stationary contacts, insert the spring in the cross arm.
6. Manually operate the controller cross arm and check for proper spring seating and contact mating.
7. Secure the contact board cover to the controller.

	<h3>WARNING</h3>
	<p>Hazardous voltage. Can cause death, serious personal injury, or property damage. Disconnect power before working on this equipment.</p>

CONTACT REPLACEMENT

Use all parts furnished in the kit. When one power pole requires contact replacement, replacing the contacts on all power poles

(For Engineering Reference Only - Rev. C)