

Ultimative Drive with Direct Drives



ac motors

DIRECT DRIVES

SIEMENS

The right drive solution for each and every task



Winding application with 1FW3 motors

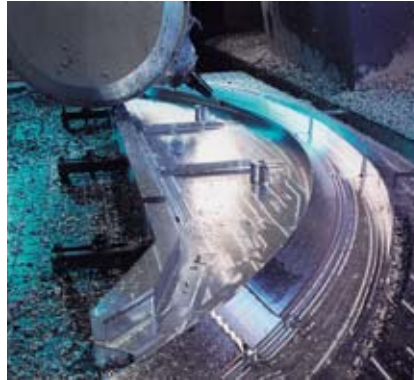

Fork positioning with 1FW6 motors



Horizontal feed axis with 1FN3

The function, performance and accuracy of the electrical components used are the deciding factors for productivity and the quality of the output from machines and systems – not to mention the mechanical execution of the task.

What's more, the drive concept also has a significant influence on the life cycle costs of a machine.

When it comes to power density, direct drives are unsurpassed. They are therefore the ideal solution when maximum dynamics and accuracy are required. In contrast to conventional motors, direct drives are integrated in the machine and transmission elements such as gearing, leadscrews or toothed belts, which are standard features of other drive types, can be omitted. This arrangement ensures a high degree of control stiffness and thus a good dynamic response and excellent precision.

A further advantage is that direct drives take up far less space in the machine.

Siemens offers two series of torque motors for high-precision rotary axis applications. 1FW3 complete torque motors for direct mounting on the machine and 1FW6 built-in torque motors for integration in the machine design.

When highly dynamic, highly precise linear axes are required, our 1FN3 linear motors are the obvious choice.

Due to the high level of integration of direct drives in the machine, special attention must be paid to certain aspects of storage and cooling, for example, that are less important when using conventional rotary servo motors.

Siemens offers not only the right direct drive for every task, but also the necessary experience and advisory expertise for supporting the user in planning the integration of the drive in his particular machine.

In addition to the standard motors described here, application-specific solutions can also be implemented on request.

Direct drives for linear/rotary axes and spindles

Component	Type	Version	Rated output	Rated speed	Rated torque/force	Page	Catalog
Linear motors – Direct drives for linear axes							
	1FN3	Synchronous linear motor Degree of protection IP65	3.1 ... 81.9 kW ¹⁾	Max. velocity at rated force Peak load 105 ... 836 m/min. Continuous load 129 ... 435 m/min.	150 ... 10,375 N	4	NC 60 NC 61
Torque motors – Direct drives for rotary axes							
	1FW3	Synchronous complete motor with hollow shaft Degree of protection IP54	3.1 ... 177 kW	150 ... 750 rpm	100 ... 7,000 Nm	8	D 21.1
	1FW6	Synchronous built-in motor Degree of protection IP23	1.7 ... 25.5 kW	Up to 430 rpm	109 ... 4,590 Nm	8	NC 60 NC 61
Direct drives for spindles							
	1PH2	Asynchronous built-in motor Degree of protection IP00	7.5 ... 31 kW	1,500 rpm	48 ... 197 Nm	12	NC 60 NC 61
	1FE1	Synchronous built-in motor High Speed Degree of protection IP00	6 ... 94 kW	2,000 ... 25,000 rpm	Up to 300 Nm	12	NC 60 NC 61
	1FE1	Synchronous built-in motor High Torque Degree of protection IP00	6 ... 103 kW	750 ... 15,800 rpm	Up to 820 Nm	12	NC 60 NC 61

NC 60: Catalog "Machine tool equipment – SINUMERIK with SIMODRIVE"
 NC 61: Catalog "Machine tool equipment – SINUMERIK with SINAMICS S120"
 D 21.1: Catalog "SINAMICS S120 – Converter chassis units 0.12 to 1,200 kW"

¹⁾ Calculated power

Linear motors – Direct drives for linear axes



1FN3 linear motor

Overview

Linear motors are highly dynamic, high-precision motors for linear traversing motions. 1FN3 synchronous linear motors supplied by Siemens consist of a secondary section with permanent magnets and a primary section under current equipped with coils.

Principle of operation

In the standard arrangement, the secondary section is fixed in the machine. By mounting a number of secondary sections side by side, it is possible to create an optional length of secondary section track. The primary section – coupled with a traversing slide supported by guide rails – is mounted above the secondary section track.

However, this arrangement can be reversed for special applications so that the secondary section becomes the moving section in the machine.

The current through the coils of the primary section is controlled in such a way as to produce a traveling magnetic field. The interaction between the magnetic fields of the primary and secondary sections creates a feed force which causes the section coupled with the traversing slide to move linearly.

A linear position measuring system is installed on the machine side alongside the secondary section track for sensing the current velocity and position.

The traversing ranges that can be achieved with 1FN3 linear motors start at approx. 20 mm and their length is limited solely by the maximum cable length for connecting the primary section or the maximum length of the position measuring system.

The secondary section is constructed by mounting secondary sections side by side spaced at 120 mm or 184 mm lengthwise.

Benefits and characteristics

Since mechanical power transmission elements and the associated backlash and frictional losses are dispensed with, linear motors boast the following characteristics:

- Outstanding dynamic response
- Very high traversing velocities
- Extremely precise
- Easy installation
- Wear-free
- Enable a simple, compact machine design
- High electrical efficiency

When suitable measuring systems and cooling methods are employed, linear motors achieve a positioning accuracy in the nanometer range.

Applications

1FN3 linear motors are therefore suitable for all applications that require high acceleration rates and velocities for highly productive handling or machining of parts.

Thus, typical applications for linear motors are:

- Machining centers
- Turning machines
- Grinding machines
- Punching/cutting machines
- Laser-cutting machines
- Machines for processing wood/glass/plastics
- Interlinking, handling, robotics
- Measuring machines
- Printing
- Electronics production (pick&place, bonders)

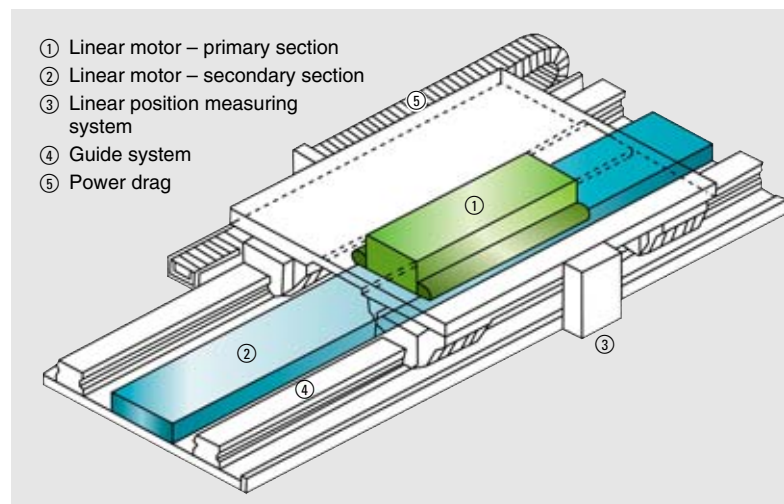

Design of the 1FN3 linear motor

Linear motors – Direct drives for linear axes

Versions and options

Different versions of the 1FN3 linear motor are available depending on the application you have in mind.

The primary section version for continuous load is ideal for machine axes with constant acceleration changes (oscillating), with high process/weight forces or for operation without water cooling.

For application profiles requiring high forces and acceleration rates for brief periods, the peak load version of the primary section is the perfect option.

The primary sections are designed as standard for water cooling. However, with the appropriate system design, natural cooling is also possible in certain cases.

In order to keep heat transfer to a minimum in precision applications, as an option both the primary and the secondary sections can additionally be equipped with a precision cooler.

An optional cover for the secondary section makes the motors extremely robust against mechanical influences.

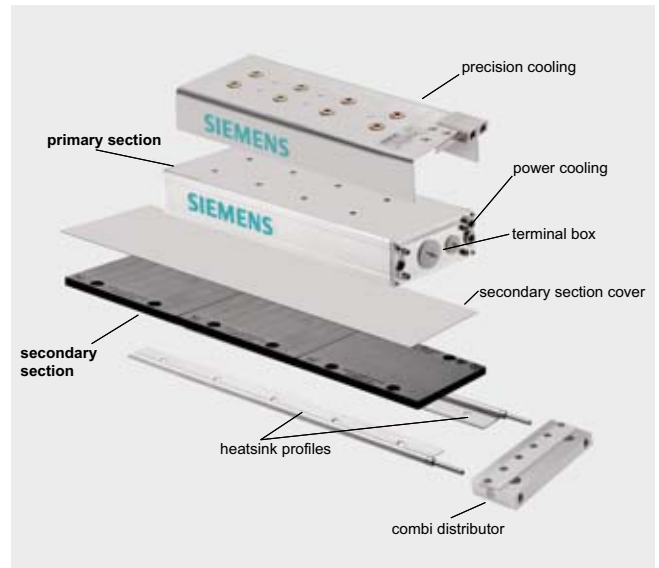

Linear motor components and options

The motors demonstrate extreme flexibility in terms of their possible configurations:

The classic single-sided arrangement is used most frequently. Alternative options include the two-track configuration or the arrangement of several primary sections on one secondary section track. This increases the force density or relieves the load on the linear guide.

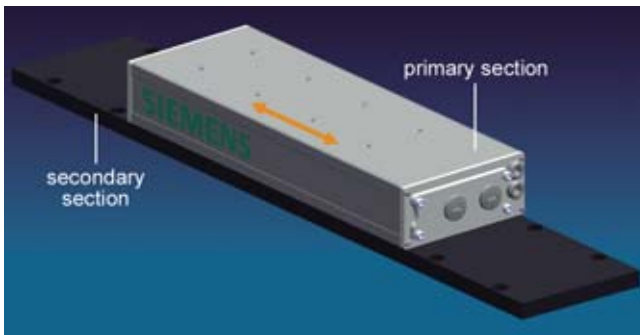

Single-sided arrangement

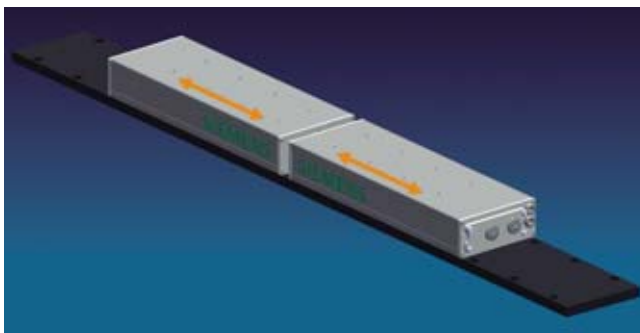

Two primary sections on one secondary section track

If several primary sections are mounted in a machine, they can be controlled by a variety of methods such as:

- By operating multiple primary sections on one converter using one position measuring signal
- By splitting the position measuring signal among several converters with one primary section each
- By a separate position measuring signal for each converter with one primary section each.

The first two variants are the preferred options in cases where there is a rigid mechanical coupling between the primary sections. The last control variant allows the primary sections to move completely independently of one another.

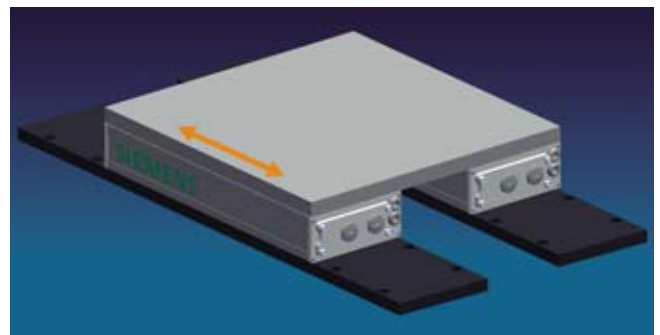

Two-track arrangement (gantry)

Linear motors – Direct drives for linear axes

1FN3 variants at a glance.

Our product range – what we have to offer							
Feedrate force	Feedrate force	Maximum velocity	Type of motor	Primary section length	Mounting width primary section with/without precision cooling	Mounting height motor with/without precision cooling	Overload factor
F_{rated} N	F_{max} N	v_{max} at F_{rated} m/min		L_p mm	b_M mm	h_M mm	
1FN3, version for peak load							
200	550	373	1FN3050	255	76 / 67	63.4 / 48.5	Max. 2.75
200 ... 1,125	490 ... 2,750	255 ... 497	1FN3100	150 ... 570	105 / 96	63.4 / 48.5	
340 ... 1,690	820 ... 4,120	282	1FN3150	150 ... 570	135 / 126	65.4 / 50.5	
615 ... 2,450	1,720 ... 6,900	176 ... 836	1FN3300	221 ... 704	150 / 141	79.0 / 64.1	
1,930 ... 3,860	5,180 ... 10,350	112 ... 519	1FN3450	221 ... 704	197 / 188	81.0 / 66.1	
2,610 ... 5,220	6,900 ... 13,800	120 ... 254	1FN3600	221 ... 704	257 / 248	86.0 / 64.1	
4,050 ... 8,100	10,350 ... 20,700	160 ... 253	1FN3900	221 ... 704	351 / 342	88.0 / 66.1	
1FN3, version for continuous load							
150 ... 300	260 ... 510	202 ... 435	1FN3050	162 ... 267	76 / 67	74.3 / 59.4	1.7
300 ... 1,205	510 ... 2,040	211 ... 307	1FN3100	162 ... 477	105 / 96	74.3 / 59.4	
455 ... 1,810	770 ... 3,060	200 ... 292	1FN3150	162 ... 477	135 / 126	76.3 / 61.4	
865 ... 3,460	1,470 ... 5,870	196 ... 257	1FN3300	238 ... 721	150 / 141	92.9 / 78.0	
2,595 ... 5,185	4,400 ... 8,810	190 ... 271	1FN3450	399 ... 721	197 / 188	94.9 / 80.0	
3,460 ... 6,915	5,870 ... 11,740	199 ... 200	1FN3600	399 ... 721	257 / 248	99.9 / 78.0	
5,185 ... 10,375	8,810 ... 17,610	129 ... 130	1FN3900	399 ... 721	351 / 342	101.9 / 90.0	

Dimension drawing

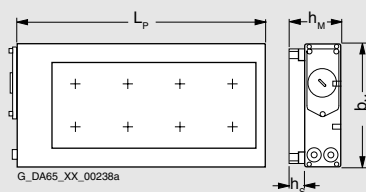

Linear motors – Direct drives for linear axes

Technical specifications	Synchronous linear motors	
		
Motor series	1FN3	
Variant	Peak load	Continuous load
Degree of protection	IP65	
Type of construction	Modular type of construction Delivered as components	
System voltage	400 ... 480 V	
Calculated power	3.1 ... 81.9 kW	1.8 ... 43.8 kW
Rated force F_{rated}	200 ... 8,100 N	150 ... 10,375 N
Maximum force F_{max}	490 ... 20,700 N	260 ... 17,610 N
Static force F_0	$0.7 \times F_{rated}$	
Traversing velocity at F_{rated}	Up to 836 m/min	Up to 435 m/min
Traversing velocity at F_{max}	Up to 383 m/min	Up to 242 m/min
Overload capability	Max. $2.75 \times F_{rated}$	$1.7 \times F_{rated}$
Connection system	Power connection via terminal box or via permanently connected power cables	
Insulation of primary section winding	Temperature class 155 (F)	
Encoder system	External encoder, depending on machine design	
Siemens drive system	SINAMICS S120, SIMODRIVE 611	
Typical applications	Applications with brief, high acceleration rates	Applications with high continuous forces
Tools		
• SINAMICS configuration	SIZER	
• SIMODRIVE configuration	SIDIM_LM, NCSD	

Torque motors – Direct drives for rotary axes

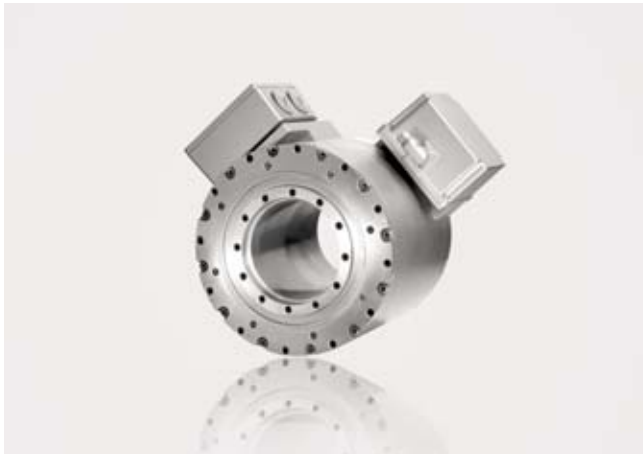

1FW3 complete torque motor

Overview

Torque motors are direct drives for rotary axes with which precision and force are required at relatively low speeds. Because their maintenance and space requirements are minimal, they are often used as an alternative to geared motors.

For applications of this kind, Siemens offers two different types of motor. The 1FW3 torque motor is a complete torque motor which, mechanically speaking, needs only to be flange-mounted to the machine and the rotor connected to the machine shaft.

1FW6 torque motors are built-in torque motors. The stator and rotor are supplied as individual components and are integrated directly in the machine.

Integrating torque motors into a machine is a high-precision operation. Our mechatronics experts will be happy to advise and support you in finding the right arrangement for your application and with the integration in the machine.

Both types of motor have a large hollow bore, with which the motor can be pushed onto the machine shaft. Alternatively, media or mechanical components can be guided through the cavity in the rotor.

Principle of operation

The 1FW3 and 1FW6 torque motors are synchronous motors, which basically operate in a comparable manner to rotary synchronous servo motors. Consequently, the rotor is equipped with permanent magnets; the stator contains the motor windings. The multi-pole design of the windings endows the motor with maximum torques at low speeds.

For speed and position control, the 1FW3 motor has a built-in shaft encoder; this must be fitted to the machine for 1FW6 motors.

The torque motors are water-cooled as standard in order to achieve a high power density. This cooling method also reduces the amount of heat transferred into the machine.



1FW6 built-in torque motor

Benefits and characteristics

Thanks to the large number of poles and because mechanical transmission elements and the associated backlash and frictional losses are dispensed with, torque motors boast the following characteristics:

- High torque
- Excellent rotational accuracy
- High acceleration capability
- Space-saving design
- Low maintenance
- High efficiency

Applications

Torque motors are ideally suited for the precise operation of rotary axes when high torques are required.

1FW6 built-in torque motors are used, for example, in machine tools for

- Rotary tables
- Swivel axes
- Fork heads
- Rotary indexing tables
- Dynamic tool magazines
- Lathe spindles

1FW3 complete torque motors are used, for example, in production machines for

- Main drives for extruders
- Worms for injection molding machines
- Roller drives for paper machines
- Winders for packaging and paper machines
- Handling and assembly systems

The right torque motor for every application: 1FW3 variants at a glance.

Our product range – what we have to offer

Rated torque range	Rated speed	Type of motor	Stator Outer diameter	Rotor Inner diameter	Housing length	Type of construction
M_{rated} Nm	n_{rated} ¹⁾ rpm		D_A mm	d_i mm	L mm	
100 ... 500	300 / 500 / 750	1FW315.	310	152	261 ... 472	IM B14
300 ... 2,000	150 / 300 / 500	1FW320.	398	152	236 ... 605	IM B14
2,500 ... 7,000	150 / 250	1FW328.	555	250	574 ... 953	IM B35

¹⁾ Rated speeds n_{rated} for operation with SINAMICS S120

Dimension drawings

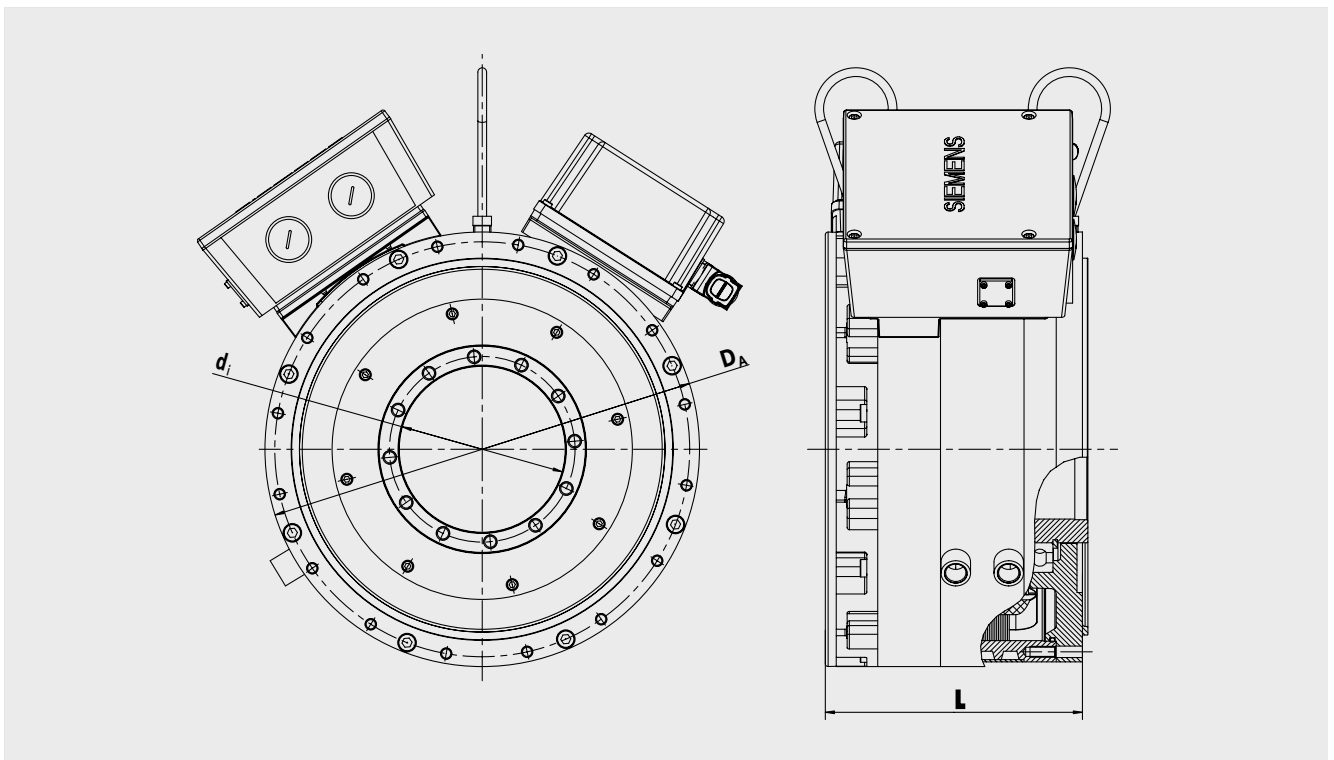

Torque motors – Direct drives for rotary axes

1FW6 variants at a glance.

Our product range – what we have to offer

Rated torque range	Maximum torque range	Rated speeds	Type of motor	Stator Outer diameter	Rotor Inner diameter	Stator Length	Cooling method
M_{rated} Nm	M_{max}	n_{rated} rpm		D_A mm	d_i mm	mm	
109 ... 338	179 ... 537	Up to 430	1FW6090	230	140	90 ... 190	Cooling jacket
217 ... 744	439 ... 1,320	Up to 310	1FW6130	310	220	90 ... 190	Cooling jacket
404 ... 1,350	716 ... 2,150	Up to 250	1FW6160	440	280	110 ... 210	Integrated cooling
605 ... 1,970	990 ... 2,970	Up to 160	1FW6190	502	342	110 ... 210	Integrated cooling
774 ... 2,440	1320 ... 3,950	Up to 130	1FW6230	576	416	110 ... 210	Integrated cooling
4,590	8,570	53	1FW6290	730	522	220	Integrated cooling

Dimension drawings

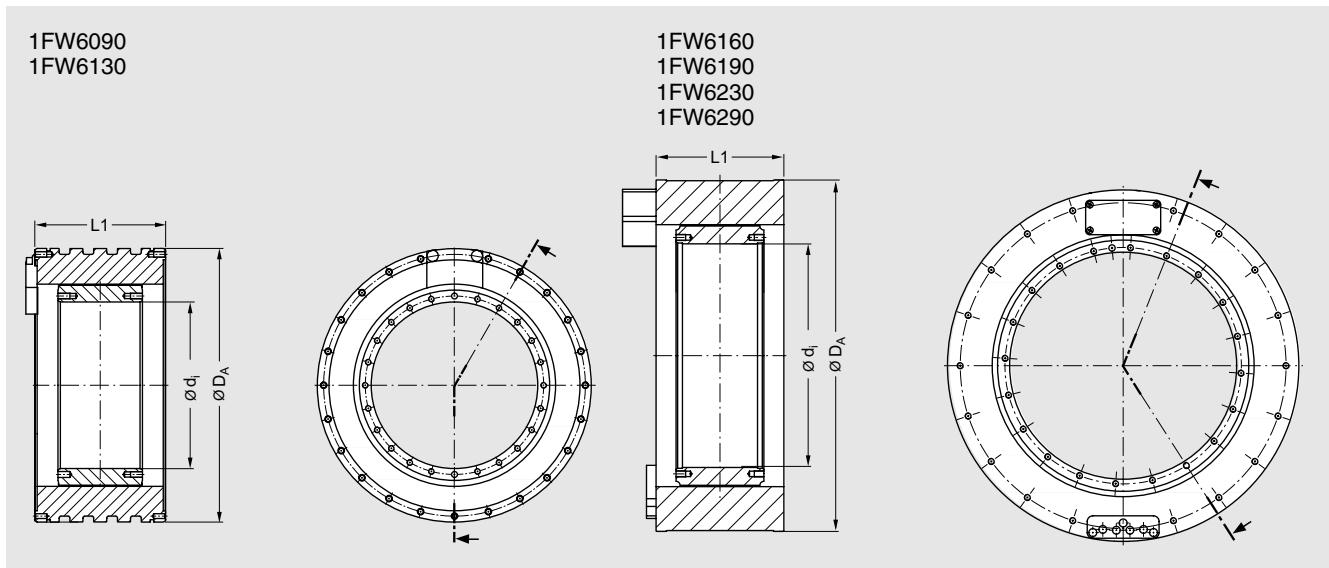

Torque motors – Direct drives for rotary axes

Technical specifications	Synchronous motor with hollow shaft (complete torque motor)	Built-in torque motor (modular)
		
Motor series	1FW3	1FW6
Cooling method	Water cooling	Water cooling
Shaft height (SH)	150 ... 280	230 ... 730 (stator outer diameter D_A)
Degree of protection	IP54	IP23 or as stated by machine manufacturer
Type of construction	IM B14 (SH 150, SH 200), IM B35 (SH 280)	Modular type of construction Delivered as components
System voltage	400 ... 480 V	400 ... 480 V
Rated power P_{rated}	3.1 ... 177 kW	1.7 ... 25.5 kW
Rated speed n_{rated}	150, 250, 300, 500, 750 rpm	Up to 430 rpm
Rated torque M_{rated}	100 ... 7,000 Nm	109 ... 4,590 Nm
Static torque/force M_0	105 ... 7,350 Nm	$0.7 \times M_{rated}$
Overload capability	$2 \times M_0$ for a short time	$1.5 \dots 1.8 \times M_0$ briefly
Max. speed n_{max}	Up to 1,700 rpm ¹⁾	Up to 900 rpm ¹⁾
Connection system	Signal connection via connectors or DRIVE-CLiQ interface Power connection via terminal box	Power and signal connection via fixed core ends, open or with connector
Insulation of stator winding	Temperature class 155 (F) for a coolant inlet temperature of up to 25 °C	Temperature class 155 (F) for a coolant inlet temperature of up to 35 °C
Sound pressure level (tolerance + 3 dB)	70 dB (A)/73 dB (A) at 4 kHz/2 kHz rated pulse frequency	Depending on machine design
Built-in encoder systems, with/without DRIVE-CLiQ interface	8-pole resolver, incremental encoder sin/cos 2048 pulses/revolution, absolute encoder EnDat 2048 pulses/revolution, no encoder required in vector mode	External encoder, depending on machine design
Siemens drive system	SINAMICS S120, SIMOVERT MASTERDRIVES MC ²⁾	SINAMICS S120, SIMODRIVE 611
Typical applications	Direct drive applications, e.g. injection molding machines, foil stretching machines, rollers and winders, rotary tables, extruders, paper machines, chopping machines	Direct drive applications, e.g. rollers and winders, rotary tables, rotary indexing tables, swivel axes, spindle machines, machine tools
Tools		
• SINAMICS configuration	SIZER	SIZER
• SIMODRIVE configuration	–	SIDIM/NCSD
• MASTERDRIVES configuration	PFAD	–
• CAD data	CAD Creator	–

¹⁾ With field weakening

²⁾ With Performance 2

Built-in motors for spindles



1PH2 asynchronous built-in motor

Overview

Users who produce their own motor spindles can obtain the right built-in motor from Siemens. These motors are characterized by their compact design, ruggedness, superior precision and accuracy.

Siemens offers three different types of built-in motors for motor spindles:

- The 1PH2 built-in asynchronous motor is employed as a compact, standard built-in motor for lathe and grinding-wheel spindles with maximum speeds of up to 10,000 rpm.
- The "High Torque" version of the 1FE1 motor is characterized by very high torques and achieves peak speeds of 20,000 rpm.
- The "High Speed" version of the 1FE1 motor is characterized by very fast acceleration rates and achieves max. speeds of 40,000 rpm.

Principle of operation, design

The 1PH2 motor is an asynchronous motor. The rotor, which is the squirrel-cage type, and the stator, which is equipped with windings, are delivered as components, which the engineer combines to form a motor spindle that he then installs in the machine.

The same applies to the 1FE1 motors. However, unlike the 1PH2 version, they are synchronous motors with a rotor that is equipped with permanent magnets.

With all these motors, water cooling is used to dissipate the heat. The position is sensed by external encoders, normally with a SIMAG H2 hollow shaft measuring system in the case of the 1PH2 motor.



1FE1 synchronous built-in motor

Benefits and characteristics

Because mechanical power transmission elements (belts, gears) and the resulting backlash are dispensed with, built-in motors boast the following characteristics:



- Excellent quality of surface finish
- High acceleration capability
- High rigidity thanks to compact design
- Wear-free
- High efficiency

Applications

Our built-in motors are ideal for use in motor spindles for machine tools:

- 1PH2 motors for grinding-wheel and lathe spindles
- 1FE1 motors for lathe, grinding-wheel and milling spindles

Built-in motors for standard and high-performance spindles

Technical specifications	Asynchronous built-in motors for standard spindles	Synchronous built-in motors for high torque and high speed applications	
			
Motor series	1PH2	1FE1	1FE1
Variant		High Torque	High Speed
Cooling method	Water cooling	Water cooling	
Stator diameter D_A	180 and 220	85 ... 280	106 ... 240
Degree of protection	IP00 or as stated by spindle manufacturer	IP00 or as stated by spindle manufacturer	
Type of construction	Delivered as components	Delivered as components	
System voltage	400 ... 480 V	400 ... 480 V	
Rated power P_{rated}	7.5 ... 31 kW	4 ... 104 kW	6 ... 94 kW
Rated speed n_{rated}	1,500 rpm	750 ... 15,800 rpm	2000 ... 25,000 rpm
Rated torque M_{rated}	48 ... 197 Nm	Up to 820 Nm	Up to 300 Nm
Overload capability	285 Nm (S6-25%)	1240 Nm (S6-25%)	465 Nm (S6-25%)
Max. speed n_{max}	Up to 10,000 rpm	Up to 20,000 rpm With field weakening	Up to 40,000 rpm With field weakening
Connection system	Free cable ends	Free cable ends	
Insulation of stator winding	Temperature class 155 (F) for a coolant inlet temperature of up to 25 °C	Temperature class 155 (F) for a coolant inlet temperature of up to 25 °C	
Sound pressure level (tolerance + 3 dB)	Depending on spindle design	Depending on spindle design	
Encoder systems, built-in	Hollow shaft measuring system: SIMAG H2 optional up to 800 pulses/revolution	External encoder, depending on machine design	
Siemens drive system	SINAMICS S120, SIMODRIVE 611		
Typical applications	Motor spindles in machine tools, e.g. lathes and grinding machines	Motor spindles in machine tools for high torque applications, e.g. lathes and grinding machines	Motor spindles in machine tools for high speed applications, e.g. grinding and milling machines
Tools			
• SINAMICS configuration	–	SIZER	SIZER
• SIMODRIVE configuration	SIDIM/NCSD	SIDIM/NCSD	SIDIM/NCSD
• CAD data	–	CAD Creator	CAD Creator

Built-in motors for spindles – 1PH2 variants at a glance.

Our product range – what we have to offer

Rated power S1	Rated torque range S1	Rated power S6-40%	Rated torque range S6-40%	Rated speeds	Maximum speeds	Type of motor	L	D	D _A	d _i
kW	Nm	kW	Nm	n _{rated} rpm	n _{rated} rpm		mm	mm	mm	mm
7.5 ... 13	48 ... 83	9 ... 15.4	57 ... 98	1,500	Up to 10,000	1PH209	250 ... 300	205	180	67
15.1 ... 31	95 ... 197	19 ... 38.6	119 ... 245	1,500	Up to 10,000	1PH211	290 ... 390	250	220	82

Dimension drawing

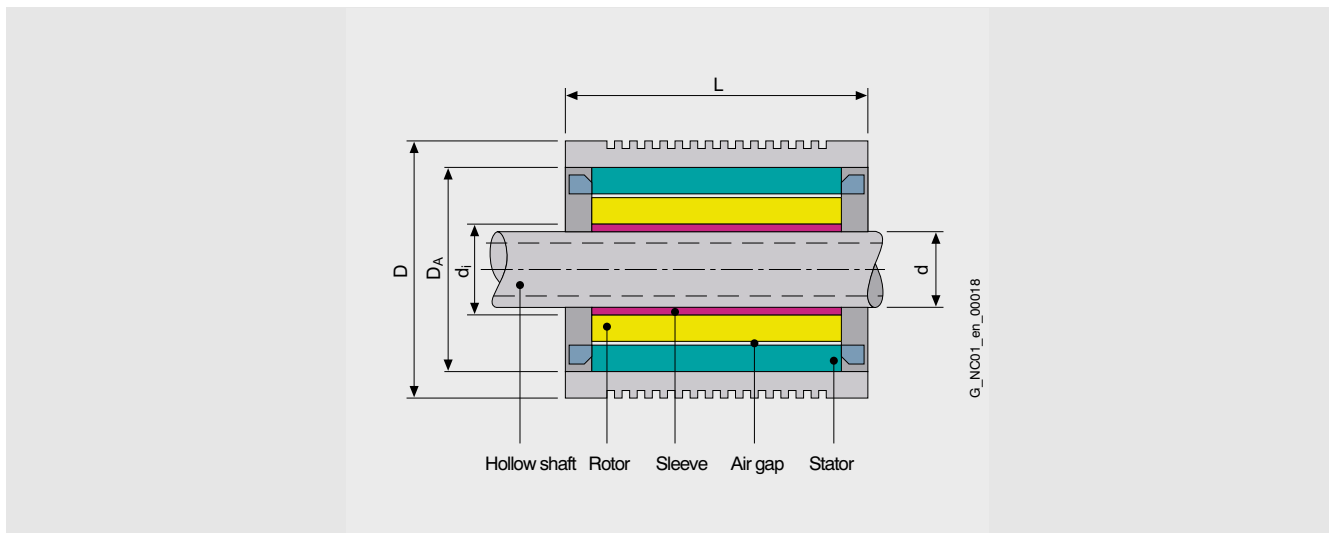

Built-in motors for spindles – 1FE1 variants at a glance.

Our product range – what we have to offer										
Rated power S1	Rated torque range S1	Rated power S6-40%	Rated torque range S6-40%	Rated speeds	Maximum speeds	Type of motor	L	D	D _A	d _i
kW	Nm	kW	Nm	n _{rated} rpm	n _{rated} rpm		mm	mm	mm	mm
High-Speed series										
6.5 ... 31.4	5 ... 20	8 ... 35	7 ... 27	7,900 ... 25,000	Up to 40,000	1FE105	130 ... 230	120	106	46
14 ... 48	28 ... 60	16 ... 51	40 ... 86	3,200 ... 9,700	Up to 24,000	1FE107	185 ... 285	155	135	58
8.8 ... 38	42 ... 105	8.8 ... 38	55 ... 140	2,000 ... 4,300	Up to 20,000	1FE108	190 ... 340	180	160	68
10.5 ... 52	24 ... 150	10.5 ... 52	35 ... 206	1,800 ... 4,500	Up to 18,000	1FE109	200 ... 400	205	180	72/80
25 ... 72.6	102 ... 204	30 ... 85	142 ... 270	1,200 ... 3,800	Up to 16,000	1FE110	265 ... 415	230	200	96
63 ... 94	200 ... 300	75 ... 112	275 ... 410	2,000 ... 3,000	Up to 14,000	1FE112	315 ... 415	270	240	110
High-Torque series										
7.4 ... 14.4	4.5 ... 11	10 ... 18	6 ... 14	10,000 ... 15,800	20,000	1FE104	107 ... 157	95	85	44/-
6.3 ... 23	10 ... 37	6.3 ... 8.3	12.6 ... 46	6,000 ... 8,000	Up to 15,000	1FE105	170 ... 320	115	103.5	42/33
4 ... 25	13 ... 56	5.3 ... 36.5	17 ... 81	3,000 ... 8,500	Up to 12,000	1FE106	130 ... 280	130	118	58/48
15 ... 34	65 ... 130	18.7 ... 42	81 ... 175	1,100 ... 5,000	Up to 9,000	1FE108	195 ... 295	190	170	93/67, 74, 80
6.3 ... 36.6	28 ... 100	7.5 ... 47	36 ... 128	1,600 ... 3,500	Up to 7,000	1FE109	150 ... 250	205	180	92/67, 80
22 ... 41.9	150 ... 300	24 ... 48.3	190 ... 384	700 ... 2,100	Up to 6,500	1FE111	260 ... 410	250	220	120/82, 102, 105
63 ... 104	430 ... 820	80 ... 124	620 ... 1,110	750 ... 1,700	8,000	1FE114	340 ... 490	310	280	166.7/ 150.3

All data refer to S1 operation

Dimension drawing

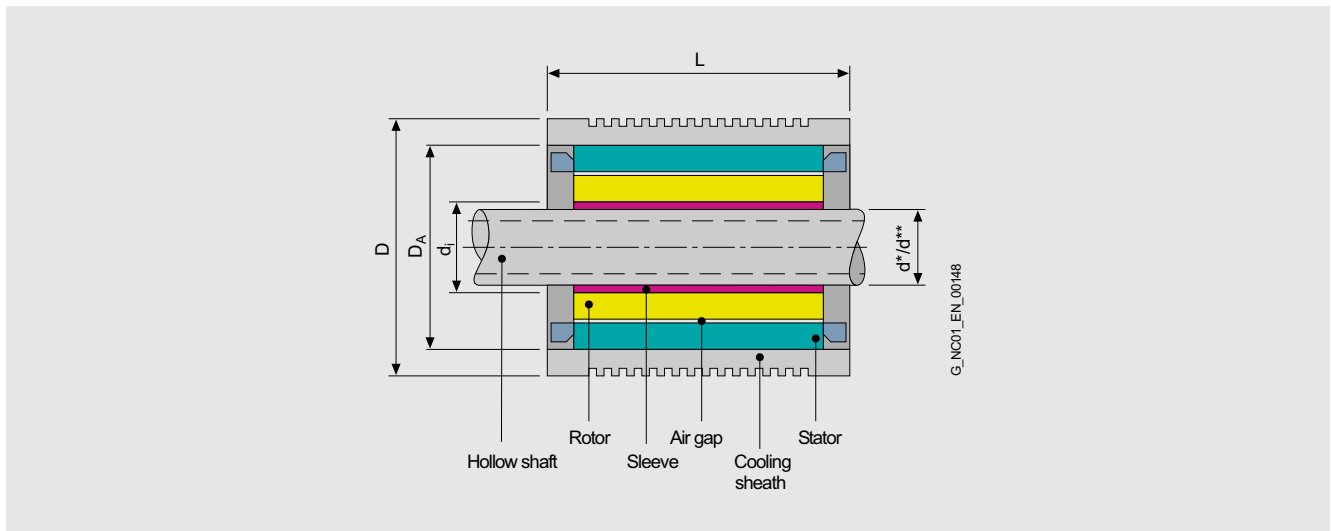

www.siemens.com/motioncontrol/motors

Siemens AG
Automation and Drives
Motion Control Systems
Postfach 31 80
91050 ERLANGEN
GERMANY

www.siemens.com/automation

The information provided in this brochure contains merely general descriptions or characteristics of performance which in case of actual use do not always apply as described, or which may change as a result of further development of the products. An obligation to provide the respective characteristics shall only exist if expressly agreed in the terms of the contract. Availability and technical features are subject to change without prior notice.

All product designations may be trademarks or product names of Siemens AG or supplier companies, the use of which by third parties for their own purposes could violate the rights of the owners.