

The real alternative ...



milling motorspindle 2SP1

SIEMENS

Standardized milling motor spindle 2SP1

Compact and 'all-inclusive' in the spindle box

Increasing requirements for higher metal removal rates with higher speeds in combination with a more compact design have resulted in the increased use of motorized spindles. With the 2SP1 series, Siemens provides motorized spindles for milling machines with an extremely attractive price/performance ratio, proving once again its expertise as a system supplier of equipment for machine tools.

Compact with all necessary spindle functions

The new motorized spindle family is optimized in terms of its performance data so that it represents a real alternative to conventional belt-driven solutions. It also consumes much less space and can be installed quickly and easily thanks to its cartridge-type design. All the important components of a motorized spindle are available. These include:

- Different types of tool interfaces (SK40, CAT40, BT40 or HSK A63)
- Pneumatic or hydraulic tool clamping and releasing mechanisms
- Rugged spindle bearings in maintenance-free greased design to absorb the machining forces
- Water-cooled drive motors in synchronous or asynchronous design
- Enclosed spindle housing with mounting flange
- Sensors for indexing and monitoring tool change

High torque output and universal application

The standardized milling motor spindle 2SP1 as standard has a high output torque and can therefore be used both for roughing and finishing. The motorized spindles are characterized by their extremely rugged construction. Different levels of performance with various output values and speed characteristic values are available, based on two different diameter sizes, whereby different output levels are possible within the same milling machine family.

There are different torque classes (40 Nm / 80 Nm / 100 Nm / 170 Nm S1 mode) and several speed classes (10,000 rpm / 15,000 rpm / 18,000 rpm) to satisfy different torque and speed requirements.

Expertise in spindle manufacture – Reliable in use

Reliable operation of the standardized milling motor spindles 2SP1 is guaranteed by the experience in spindle manufacturing gained by the company Weiss Spindeltechnologie GmbH over many years and the expertise of Siemens in control and drive systems for machine tools.

This mechatronic unit is a symbiosis of high-quality mechanical engineering and bearing technology combined with the latest motor technology and electronics. Motorized spindles are manufactured by Weiss.

Weiss Spindeltechnologie GmbH
A Siemens Company
Rudolf-Diesel-Str. 35
97424 SCHWEINFURT
GERMANY

Economical standard solution with a number of advantages

The standardized milling motor spindle 2SP1 is the ideal drive solution for main spindles in standard milling machines and machining centers and offers the customer significant advantages in comparison with conventional belt-driven solutions:

- The complete solution is comparable with belt-driven solutions and more economical than the classical customized motorized spindle designs
- Hydraulic or pneumatic tool clamping and releasing mechanisms depending on customer preference
- Thanks to the pneumatic tool clamping and releasing mechanisms, a hydraulic unit is not required
- Integrated sensors (for indexing and monitoring tool change)
- Higher max. speed and shorter acceleration time compared to conventional solutions
- Drive train with greater rigidity
- More compact solution
- Fewer parts and easier installation
- Extreme short tool change times with 2SP120 by a 2-channel system and an optional retaining collet
- Worldwide supply of complete systems including spindle mechanics from a single source from Siemens

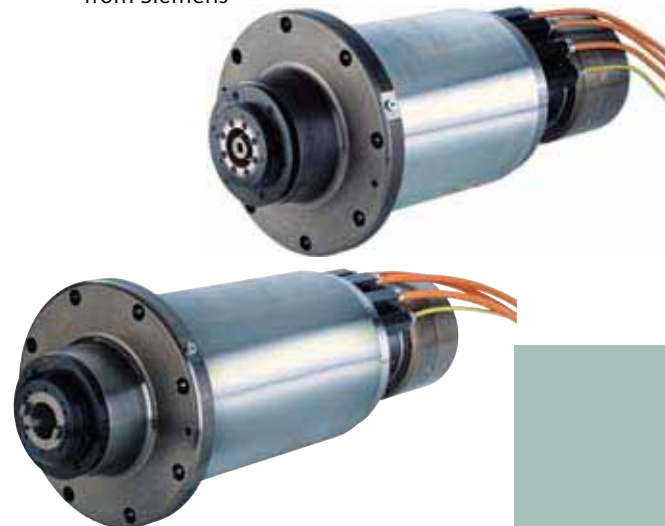

Design of the standardized milling motor spindle 2SP120

Standard functions

- Tool interface
 - HSK A63
- Tool clamping device
 - Released by pneumatic cylinder 6 bar
 - Clamping cup springs
- Tool cleaning
 - Compressed air through draw-bar 5 ... 6 bar
- Working position
 - Horizontal / vertical
- Housing
 - Cartridge with flange mounting
- Bearing lubrication
 - Grease, permanently lubricated
- Front bearing seal
 - Sealing air 1 ... 1.5 m³/h
 - Filter mesh 8 µm
- Hollow-shaft encoder
 - Incremental, sin/cos 1 V_{pp} 256 S/R with zero indication
- Motor temperature sensor
 - KTY84-130
 - PTC thermistor drilling for full motor protection
- Sensor (analog) for clamping status
 - Tool clamped
 - Draw-bar in release position
 - Clamped without tool
- Sensor (digital)
 - for position status release piston
- Cooling
 - Water, max. 5 bar, 10 l/min
 - Max. 25% anticorrosion fluid Clariant Antifrogen N or Tyfocor
 - Filter mesh 100 µm
- Media connections
 - 2 x flexible tube connector Ø 10/12 mm, coolant
 - 1 x G 1/8 radial and Ø 5 mm axial, air barrier
 - 1 x G 1/4, taper cleaning air separate connection at the spindle back
 - 1 x G 1/4, pneumatic tool release
 - 1 x G 1/8, pneumatic tool clamping
- Electrical connections
 - Power via 1.5 m cable
 - Sensors via signal plugs

High feature options

- Internal tool cooling
 - 50 bar, up to 54 l/min
 - Filter mesh 50 µm acc. to -/16/13 ISO 4406
 - 1 x G1/4, cooling lubrication,
 - 1 x G1/8, leakage
- Max. speed
 - 18,000 rpm
- Tool clamping device
 - Release by hydraulic cylinder 80 bar
 - Clamping by cup springs
 - 1 x G 1/4, hydraulic tool release
 - 1 x G 1/4, hydraulic tool clamping
- Ring for external tool cooling
- Power connector
 - size 1.5: 2SP1202
 - size 3: 2SP1204
- Retaining collet (270 N holding force)
- Sensor for clamping status digital

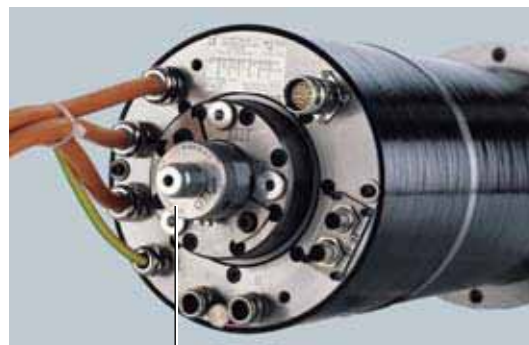
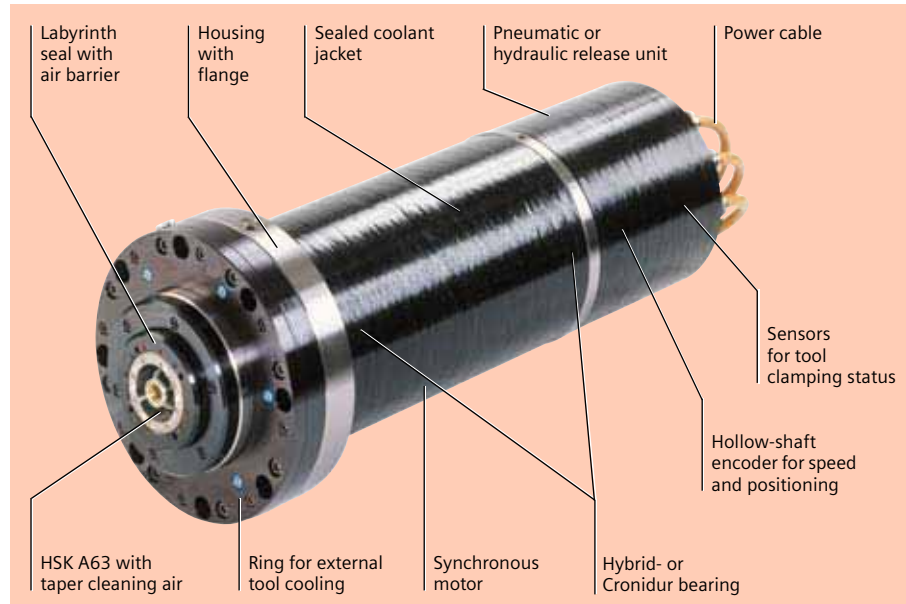

Rotary unit for internal tool cooling



Design of the standardized milling motor spindle 2SP125

Standard functions

- Tool interface:
 - SK 40 for tools with asymmetrical slot arrangements
- Tool clamping device
 - Released by pneumatic cylinder 6 bar
 - Clamping cup springs
- Tool cleaning
 - Compressed air through draw-bar 5 ... 6 bar
- Working position:
 - Horizontal / vertical
- Housing:
 - Cartridge with flange mounting
- Bearing lubrication
 - Grease, permanently lubricated
- Front bearing seal
 - Sealing air 1.0 ... 1.5 m³/h
 - Filter mesh 8 µm
- Hollow-shaft encoder
 - Incremental, sin/cos 1 V_{pp} 256 S/R with zero indication
- Motor temperature sensor
 - KTY84-130
- Sensor for clamping status
 - Tool clamped
 - Draw-bar in release position
 - Clamped without tool
- Cooling
 - Water, max. 5 bar, 10 l/min
 - Max. 25% anticorrosion fluid Clariant Antifrogen N or Tyfocor
 - Filter mesh 100 µm
- Media connections
 - 2 x G 1/2 (Ø 9 mm), cooling
 - 1 x G 1/8 (Ø 8 mm), air barrier
 - 1 x G 1/4, taper cleaning air
 - 1 x M16x1.5 pneumatic tool release
 - 1 x G 1/8, pneumatic tool clamping
- Electrical connections
 - Power via 1.5 m cable
 - Sensors via signal plugs

High feature options

- Internal tool cooling
 - 50 bar, up to 54 l/min
 - Filter mesh 50 µm acc. to -I16/13 ISO 4406
 - 1 x G1/4, cooling lubrication,
 - 1 x G1/8, leakage
- Max. speed
 - 15,000 rpm (with HSK A63)
- Tool interface
 - BT 40
 - CAT 40
 - HSK A63

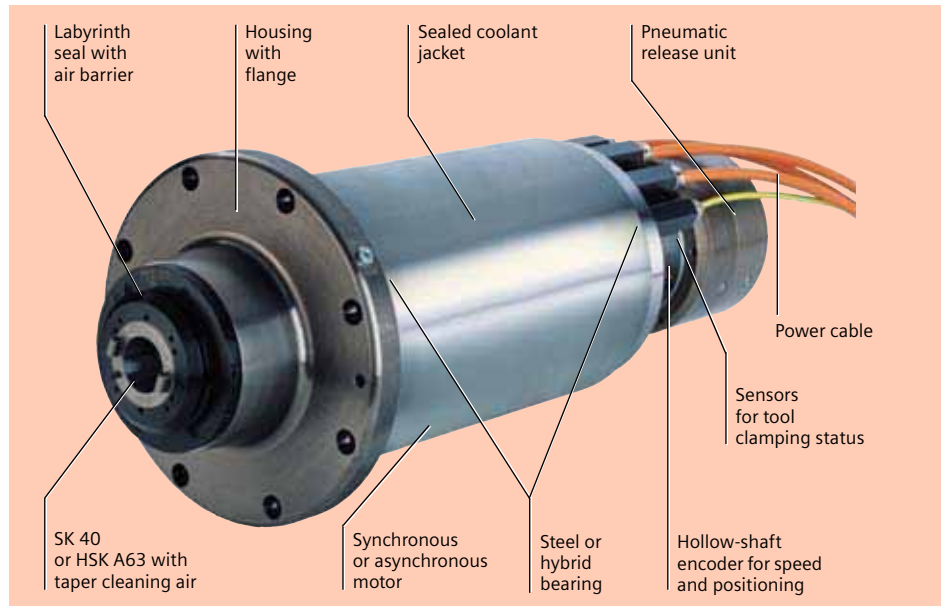

Dimensions of the standardized milling motor spindle 2SP1

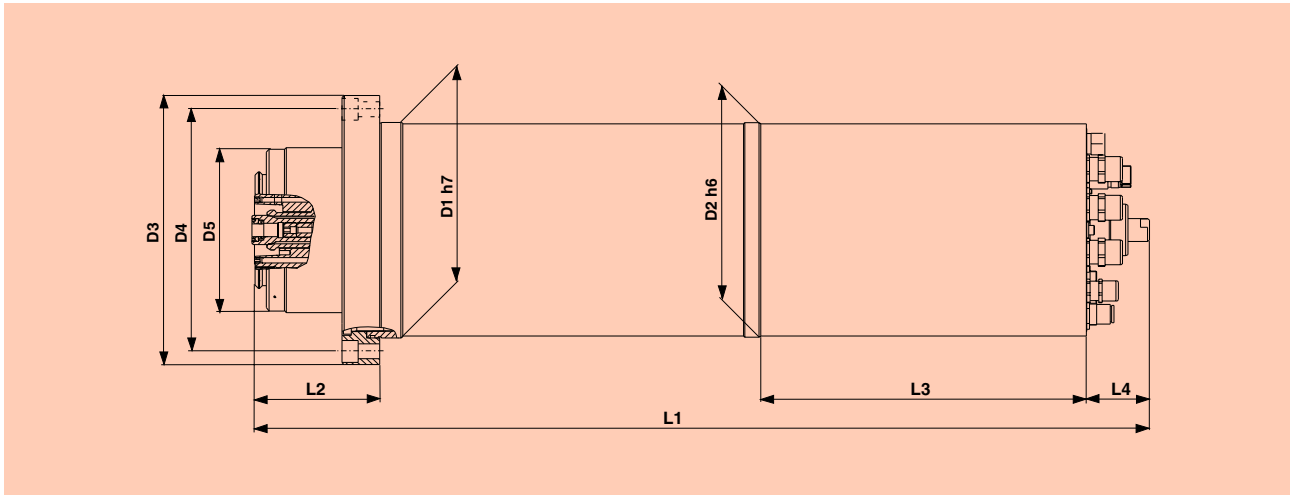

2SP120

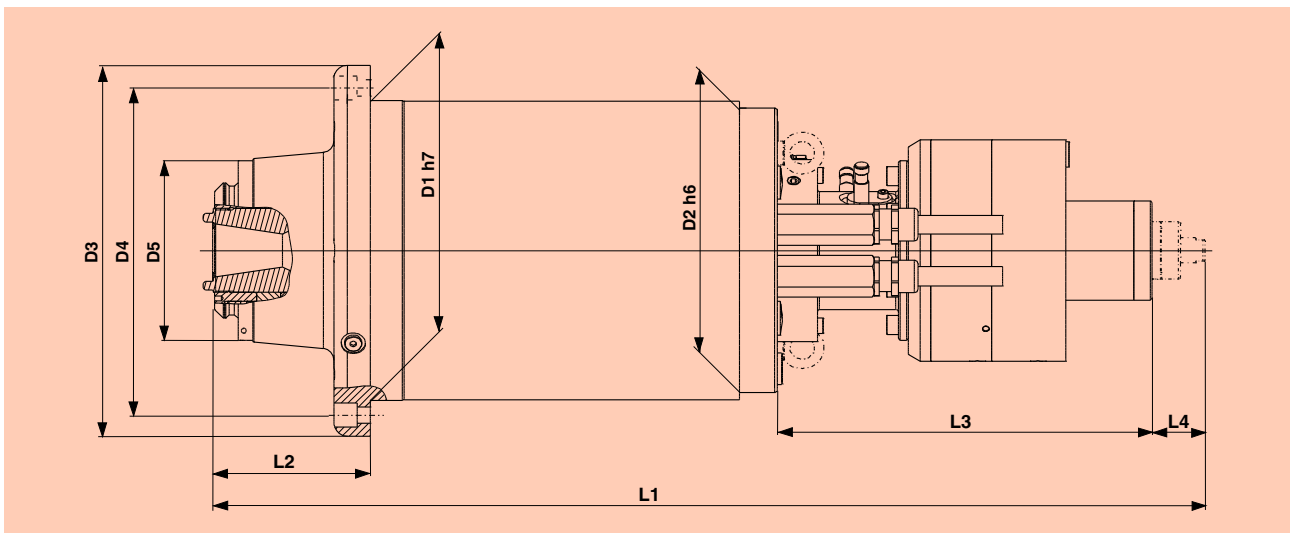

2SP125

	D1 mm	D2 mm	D3 mm	D4 mm	D5 mm	L1 ¹⁾ mm	L2 mm	L3 mm	L4 mm
2SP1202	200	199	250	225	150	735 ⁴⁾	115.5	309 ⁴⁾	58 ⁴⁾
2SP1204	200	199	250	225	150	835 ⁴⁾	115.5	309 ⁴⁾	58 ⁴⁾
2SP1253 ²⁾	250	237	310	275	150	813	124.4	310	43
2SP1255 ²⁾	250	237	310	275	150	913	124.4	310	43
2SP1253 ³⁾	250	237	310	275	150	819	130.0	310	43
2SP1255 ³⁾	250	237	310	275	150	919	130.0	310	43

¹⁾ Without rotary feedthrough unit, the spindle length is shorted by approx. 43 mm

²⁾ Tool interface HSK A63

³⁾ Tool interface SK40, CAT40, BT40

⁴⁾ With hydraulic tool clamping device, the spindle length L1 is approx. 118 mm shorter, L3 is approx. 147 mm shorter and L4 is approx. 30 mm longer

Standardized milling motor spindle 2SP1

Spectrum of standardized milling motor spindles 2SP1

Order No.	Rated power S1 kW	Rated torque S1 Nm	Rated speed rpm	Rated current S1 A	Rated power S6-40% kW	Rated torque S6-40% Nm	Rated power S1 kW	Rated torque S1 Nm	Rated speed rpm	Rated current S1 A	Maximum speed rpm
Synchronous											
Star operation							Delta operation				
2SP1202-1HA ■■-1D ■■	12.0	42	2,700	30	12.0	55					15,000
2SP1202-1HB ■■-2D ■■	15.5	42	3,500	42	15.5	55					18,000
2SP1204-1HA ■■-1D ■■	26.4	84	3,000	60	26.4	110					15,000
2SP1204-1HB ■■-2D ■■	35.0	78	4,300	79	35.0	110					18,000
Asynchronous											
2SP1253-8HA0 ■-0 ■■ 2	13.2	70	1,800	28	18.9	100	13.2	32	4,000	29	10,000
2SP1253-8HA0 ■-1D ■ 2	13.2	70	1,800	28	18.9	100	13.2	32	4,000	29	15,000
2SP1255-8HA0 ■-0 ■■ 2	11.7	140	800	30	16.7	200	11.7	62	1,800	29	10,000
2SP1255-8HA0 ■-1D ■ 2	11.7	140	800	30	16.7	200	11.7	62	1,800	29	15,000
Synchronous											
2SP1253-1HA0 ■-0 ■■ 2	26.0	100	2,500	53	29.0	130					10,000
2SP1253-1HB0 ■-1D ■ 2	35.0	100	3,300	68	38.0	130					15,000
2SP1255-1HA0 ■-0 ■■ 2	46.3	170	2,600	95	55.0	236					10,000
2SP1255-1HB0 ■-1D ■ 2	53.4	170	3,000	120	64.0	236					15,000

Options for standardized milling motor spindles 2SP1

Electronical connections

2: power via 1.5 m cable without connector, signal connectors for the sensors
6: power via 1.5 m cable and connector size 1.5 (only 2SP1202)
or connector size 3 (only 2SP1204),
signal connectors for the sensors

Sensors

D: Sensor "Tool clamped",
Sensor "Draw-bar in release position",
Sensor "Clamped without tool"
F: D + Sensor "Position release piston" (only 2SP120)

Tool interfaces

A: SK 40 tool interface
B: BT 40 45° tool interface
C: CAT 40 tool interface
D: HSK A 63 tool interface
E: BT 40 30° tool interface
R: HSK A63 tool interface with retaining collet (only 2SP120)

Cooling

1: closed cooling jacket
3: closed cooling jacket and internal tool cooling
4: closed cooling jacket and ring for
external tool cooling (only 2SP120)
5: closed cooling jacket, internal tool cooling
and ring for external tool cooling (only 2SP120)

Tool clamping- and -releasing device

0: pneumatic (only 2SP125)
2: pneumatic (only 2SP120)
3: hydraulic (only 2SP120)

You can find information about this product
on the Internet at:



<http://www.siemens.de/motioncontrol/motoren>
<http://www.weissgmbh.de/fraesen.php>
<http://www.siemens.com/sinumerik>

You can e-mail us at:



sinumerik@erlf.siemens.de

All product designations may be trademarks or product names of Siemens AG or supplier companies whose use by third parties for their own purposes could violate the rights of the owners.

The information provided in this brochure contains descriptions or characteristics of performance which in case of actual use do not always apply as described or which may change as a result of further development of the products. An obligation to provide the respective characteristics shall only exist if expressly agreed in the terms of contract. Availability and technical specifications are subject to change without notice.